

Panel PC

10.4" SUPER Fanless Bezel-free Panel PC



Touch Screen



31385CW Back Panel



31385CW Back Panel (Option)

Feature :
Fanless, Touch Screen, IP65 Front Panel Water Proof, LED Backlight panel

Application:
Information Kiosk, POS, Mobile solution, Automation Control

Panel PC Information

LCD Panel	AUO
Resolution	1024 x 768
Luminance (cd/m2)	400
Contrast Ratio	700:1
Backlight	LED
Viewing Angle (H-V)	80 / 80 / 60 / 70 CR≥10 (L / R / U / D)
Touch Screen	Resistive Touch screen (Capacitive touch screen-option)
Mounting Spec.	VESA 75
Panel frame water proof	IP65
Accessory (Option)	Wall Mount Kit / Stand

Bezel Free Panel PC

Dimension	296W x 66.79H x 250.4D mm 296W x 80.1H x 250.4D mm (Optional)
Chassis Material	Plastic
Weight	1.9kg (Incl. M/B)
Storage Space	mSATA / 1 x 2.5" HDD
Operation Hymidity	5 ~ 90% @ 39 °C, non-condensing

M/B information: (Please refer to M/B specification)

CPU Type	M/B Model	VGA	COM	LAN	USB	Other Function	Operation Temp.	
							mSATA	HDD
Intel® Bay-Trail E3845 / J1900	31385CW	1	4	2	4	2 x mini Card DC IN +9~36V	60°C	50°C

Optional Functions

3G / 4G	Wi-Fi	Bluetooth	High Brightness Panel	GPS	Rechargeable Battery
---------	-------	-----------	-----------------------	-----	----------------------

The above available functions outline the possibility with system, please contact us for more information.

Dimension

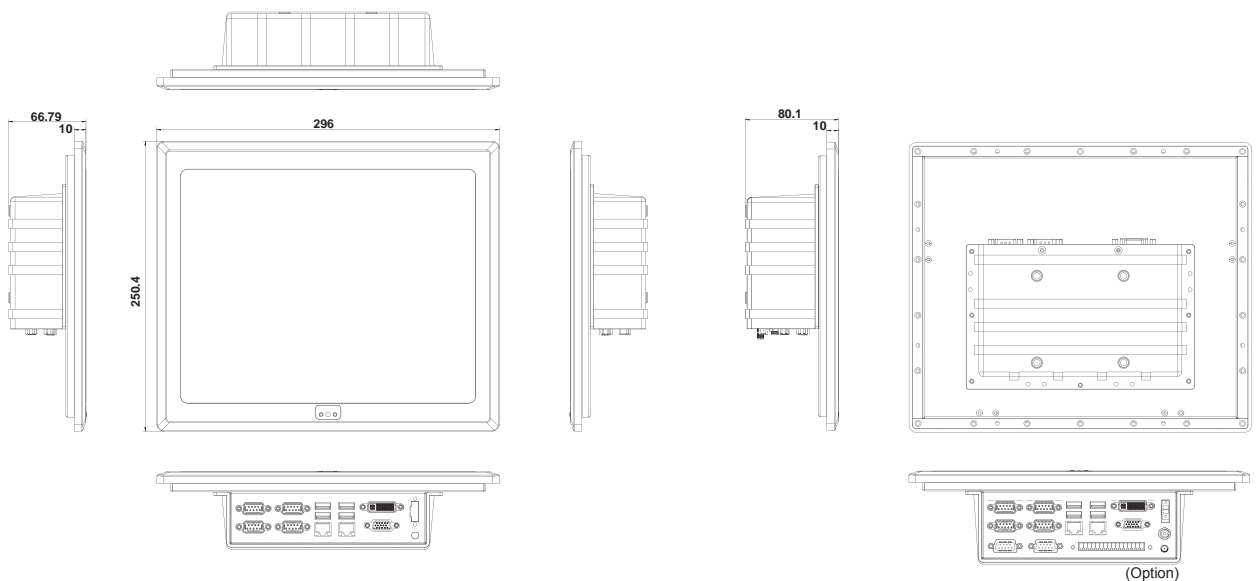

(Option)