



VEX-SOM

with

DM&P Vortex86EX
400MHz processor with FPU

Version 2.0

Copyright

The information in this manual is subject to change without notice for continues improvement in the product. All rights are reserved. The manufacturer assumes no reasonability for any inaccuracies that may be contained in this document and makes no commitment to update or to keep current the information contained in this manual.

No part of this manual may be reproduced, copied, translated or transmitted, in whole or in part, in any form or by any means without the prior to written permission of ICOP Technology Inc.

©Copyright 2015 ICOP Technology Inc

Trademarks Acknowledgement

Vortex86EX™ is the registered trademark of DM&P Electronics Inc.

Other brand names and product names that appear in this document are the properties and registered trademarks of their respective owners. All names mentioned herewith are served for identification purpose only.

Revision History

Revision		Date	Remark
Ver 1.0	Aug 14, 2014		First release.
2.0	July 23, 2015		New version released

Table of Contents

1	General Information.....	1
1.1	Overview	1
1.2	Block diagram.....	2
1.3	Specifications	3
1.4	Ordering Information	5
2	Hardware Information	6
2.1	Dimension.....	6
2.2	Connectors (for module)	8
2.2.1	Onboard connector	8
2.2.2	Matching connector.....	8
2.3	Recommended Layout (for module).....	9
2.4	Pin Assignments & Jumper Setting.....	10
2.4.1	Board pin assignment.....	10
2.4.2	J1:JTAG.....	12
2.5	Pin Table List.....	12
2.6	Signal Description.....	13
3	Electrical Characteristics.....	16
3.1	Pull-up/Pull-down Description.....	16
3.2	DC Characteristics	16
4	CrossBar I/O Selection	17
4.1	CrossBar I/O overview	17
4.2	Usage of SocCfg Tool.....	19
4.3	Setup the CrossBar I/O.....	20
5	Software Resources.....	21
5.1	BIOS	21

5.2 Software.....	21
6 ADC	22
6.1 ADC overview.....	22
6.2 ADC Characteristic.....	22
6.3 ADC Sample code	22
7. Evaluation Board	23
Warranty.....	24

1 General Information

1.1 Overview

The VEX-SOM is a 45x28mm, 128 pins, single +5V input, System On Module with onboard CPU, DRAM and SPI Flash; also take advantage of Vortex86EX CrossBar I/O as a powerful, flexible, tiny and low power module.



1.2 Block diagram

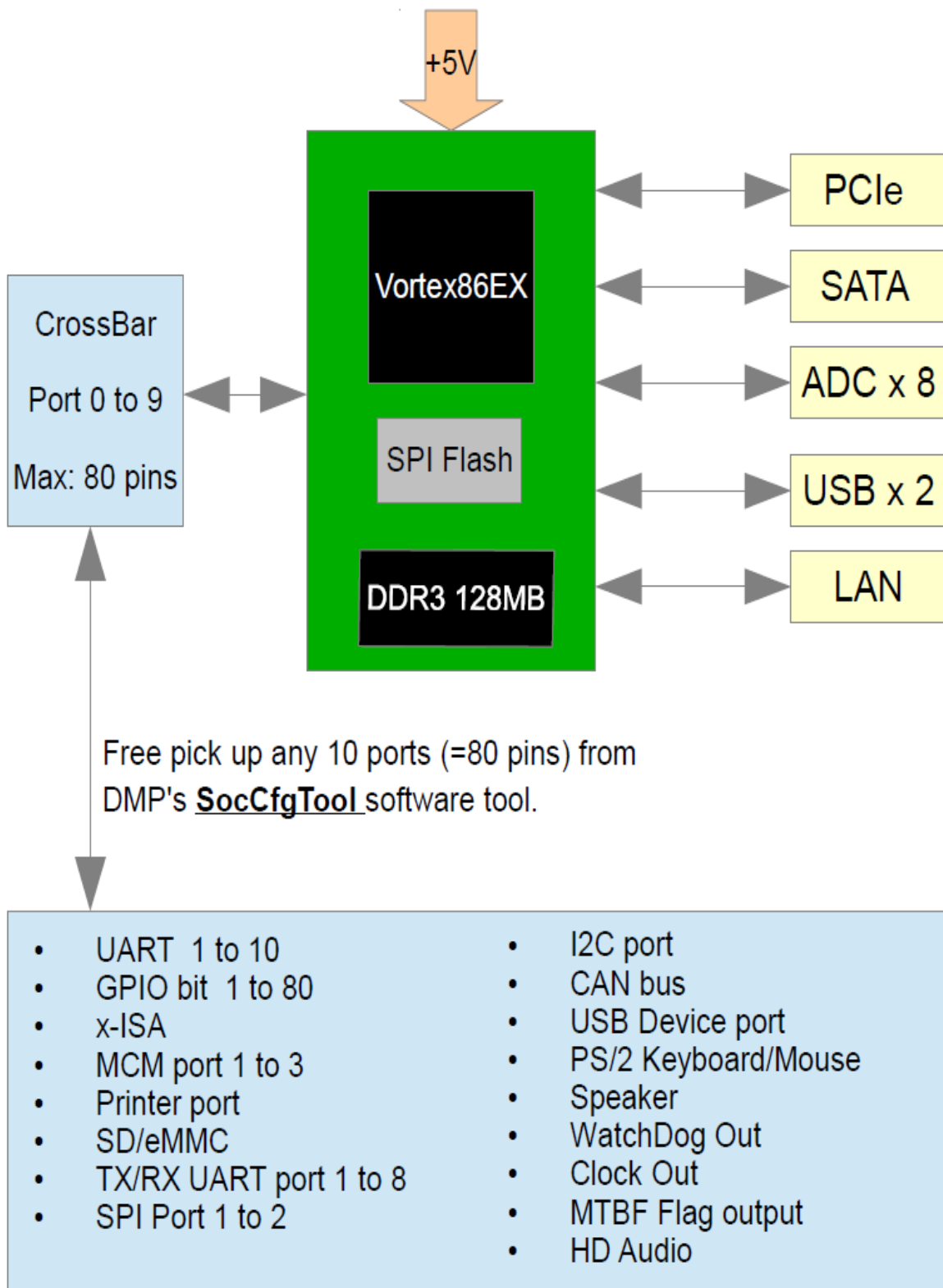

1.3 Specifications

Processor	DM&P SoC CPU Vortex86EX 400Mhz with FPU			
Cache	L1: I/D-Cache 16/16KB, L2:128KB			
System Memory	128M DDR3 Onboard			
Flash Disk Support	4MB, include 512KB for BIOS			
I/O Interface	Integrated 10/100Mbps Ethernet x1 SATA v1.0 x 1 port (Secondary IDE Channel) PCIe v1.1 x 1 port ADC 11-bit x 8 channels			
I/O CrossBar Programmable 10 ports (=80 pins)	Function	Description	Maximum	Unit
	GPIO	General Purpose Input/Output	80	bit
	UART	16C550/16C552 compatible	10	port
	TX/RX UART	UART with only TX/RX pin	8	pair
	UART TXDEN	RS485 Auto direction control	8	bit
	x-ISA	x-ISA bus is the light version of ISA bus, with only 1 DMA channel, selectable for 8/16 bit and all other signals	1	bit/ port
	MCM	Motion control module	3	port
	Printer	Printer port	1	port
	SD/MMC	SD / eMMC , SD version 2.0.	1	port
	SPI	Serial Peripheral Interface	2	port
	CAN	Controller Area Network	1	port
	I2C	Inter-Integrated Circuit	1	port
	USB	USB Device port,	1	port

	Device	version:1.1		
	LAN LED	Link and Duplex LED for build-in Ethernet	2	bit
	Keyboard	PS/2 Keyboard	1	port
	Mouse	PS/2 Mouse	1	port
	WDTOUT	WatchDog timeout signal	1	bit
	CLK OUT	Clock output select from 14.318MHz /24MHz /25MHz/ ISA Clock	1	bit
	MTBF	MTBF flag output	1	bit
	HD Audio	High Definition Audio	1	port
Power Requirement	5V @ 380 mA (typical)			
Weight	10g			
Dimensions	45mm x 28mm x 7mm (1.77 x 1.1 inches)			
Operating Temp.	-20°C ~ 70°C -40 ~ +85 (optional)			
Operating System Support	<ul style="list-style-type: none"> - DOS - Linux (Kernel 2.6.24 or later, i486 mode) - Windows CE 5.0 , CE 6.0 , Compact 7 - Windows XP or XP Embedded - VxWorks 5.5 & 6.8 - QNX 6.3.2 - FreeBSD, OpenBSD and NetBSD. - Other real time OS has 486 supports, for example RTOS-32. 			

1.4 Ordering Information

Product Name	Description
VEX-SOM	Vortex86EX SOM128pin CPU Module with 128MB DDR3
VEX-SOM-X	Vortex86EX SOM128pin CPU Module with 128MB DDR3 -40°C ~+85°C support
VEX-SOM-DEV	VEX-SOM Development Board*1 MINIPCIE VGA cable*1 GPIO cable*5 Mini PCI VGA Board*1 Mini PCI express to PCI express converter*1 PRINT PORT cable*1 PS2 cable(1 Male to 2 Female)*1

2 Hardware Information

2.1 Dimension

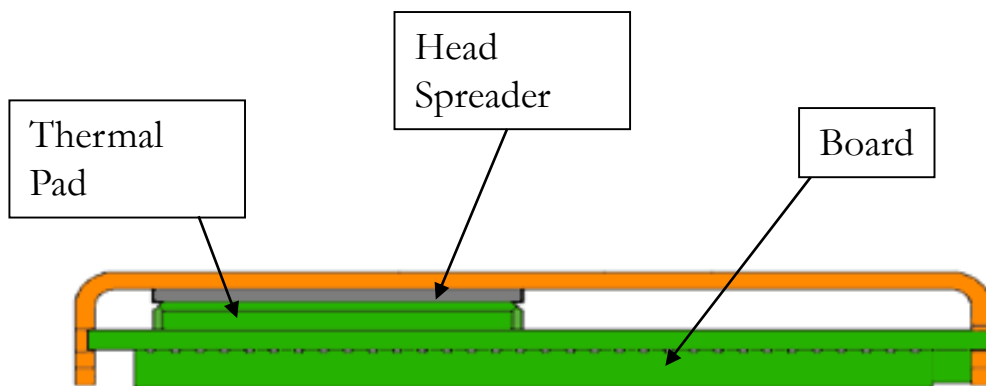
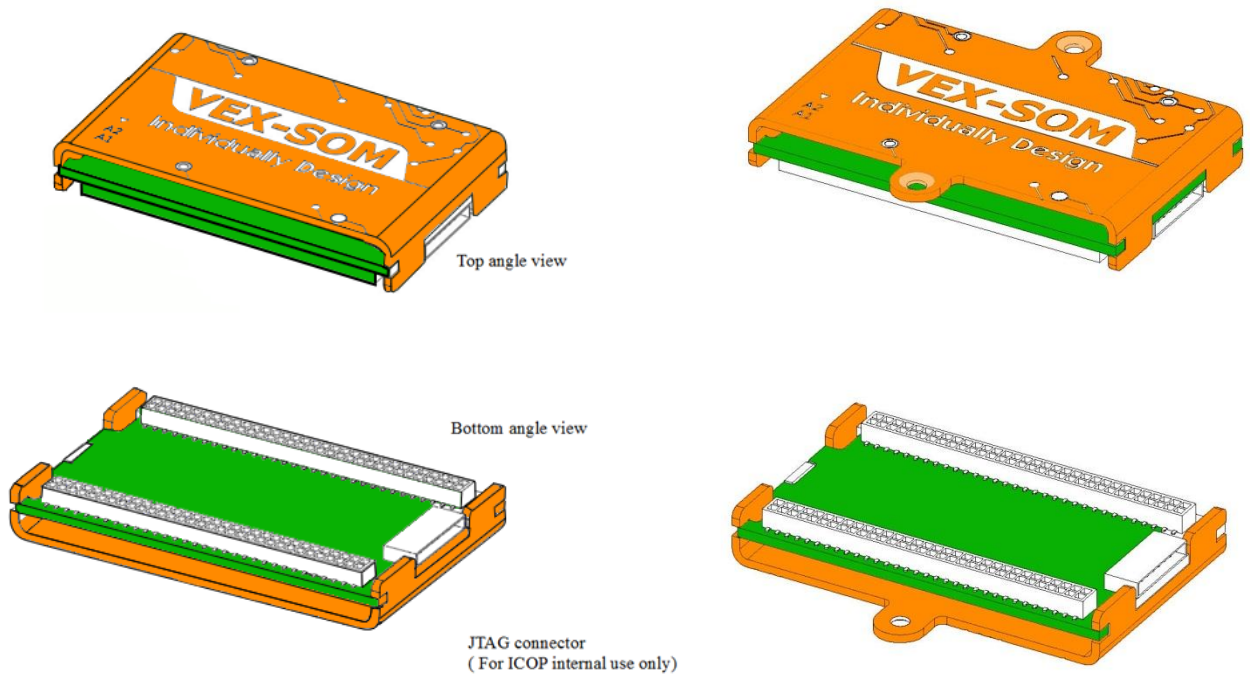

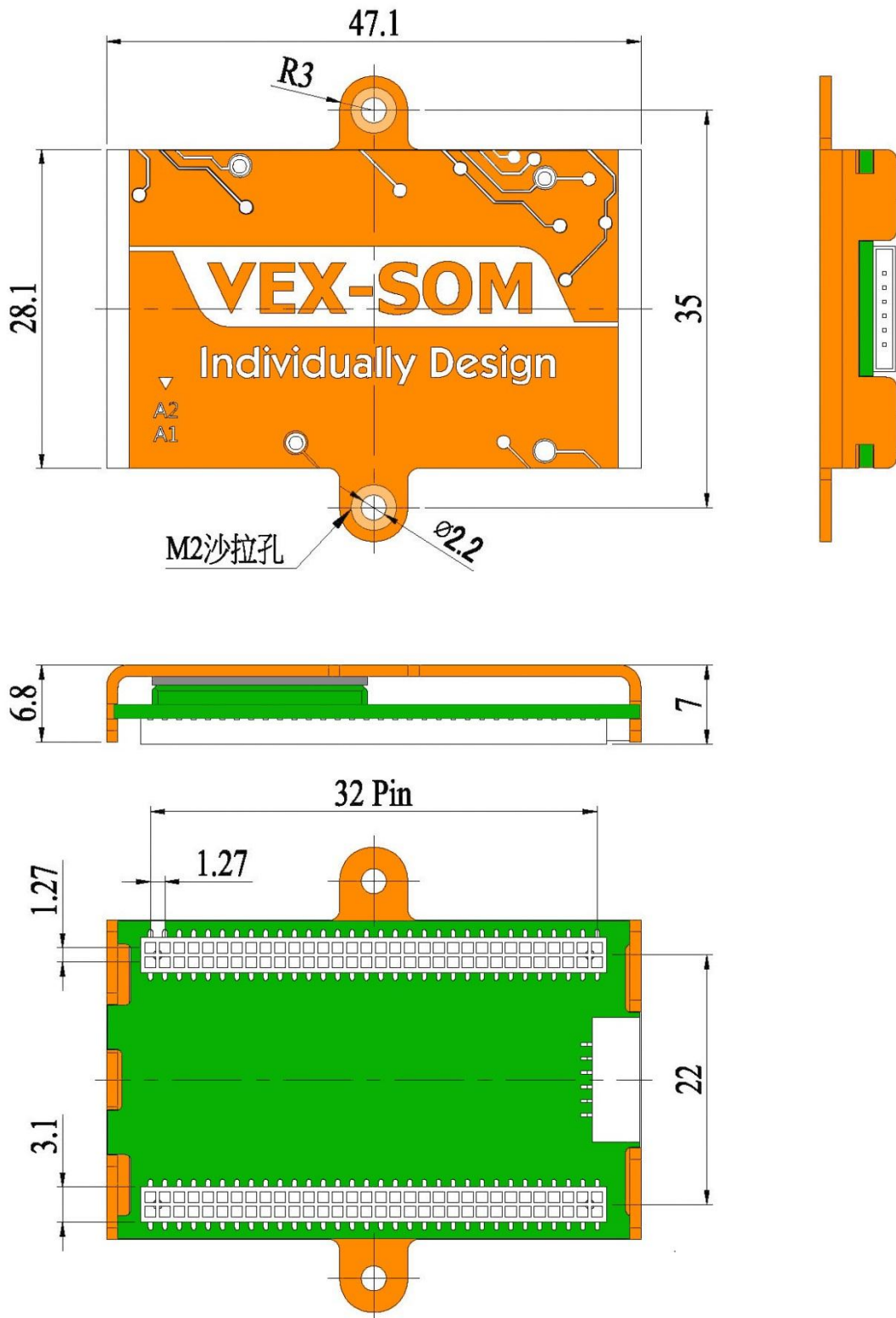

2.2 Connectors (for module)

2.2.1 Onboard connector

- Vendor: Conn Top Component INC
- Item number : P3N23-232D1BKC000I

2.2.2 Matching connector

On the carrier board, it needs 2 pcs of matching connectors, belows are two options, and you can choice either one by your convenience.

- Option 1: (Note)
Vendor: Conn Top Component INC.
Conn Top item number : H3N25-232D1BKC002F
ICOP item number : PH2*32(1.27)-5.3MM
- Option 2:
Vendor: Samtec.
Item number : FTSH-132-02-F-DV

(Note): Customer can buy “Opition 1” connector for ICOP, ICOP item number is PH2*32(1.27)-5.3MM, please contact ICOP sales if you need this connector.

2.3 Recommended Layout (for module)

Please keep the whole area empty between two matching connector on your carrier board.

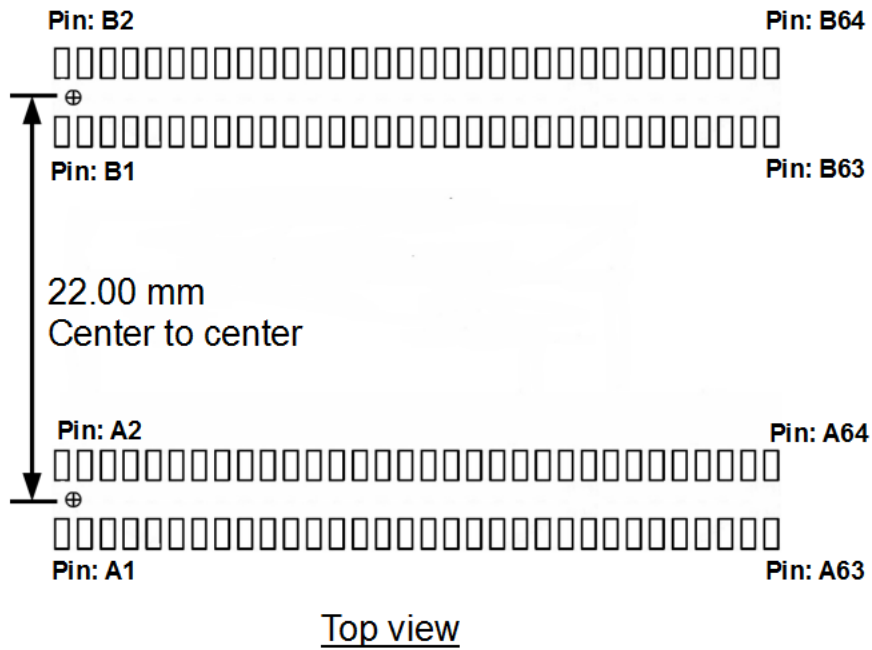

2.4 Pin Assignments & Jumper Setting

2.4.1 Board pin assignment

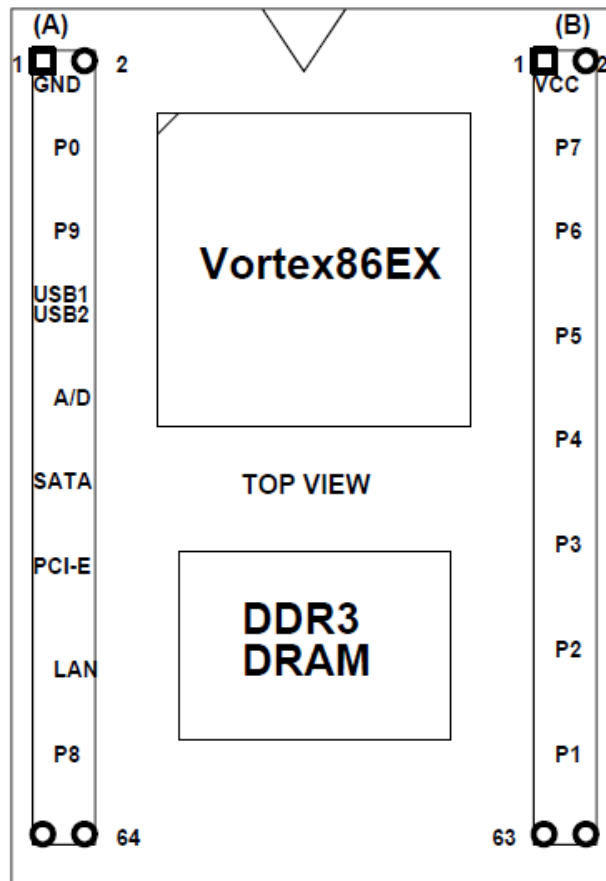

As the image above, there are two connector on VEX-SOM; Pin A1~A64 is on the left and Pin B1~B64 is on the right. Please see the pin assignments on the next page.

Pin#	Single Name	Pin#	Single Name
A1	RSTDRV	A2	VSS
A3	GP00	A4	GP01
A5	GP02	A6	GP03
A7	GP04	A8	GP05
A9	GP06	A10	GP07
A11	GP90	A12	GP91
A13	GP902	A14	GP93
A15	GP94	A16	GP95
A17	GP96	A18	GP97
A19	VSS	A20	VSS
A21	USBD1-	A22	USBD2-
A23	USBD1+	A24	USBD2+
A25	AGND	A26	AGND
A27	ADC_0	A28	ADC_1
A29	ADC_2	A30	ADC_3
A31	ADC_4	A32	ADC_5
A33	ADC_6	A34	ADC_7
A35	VSS	A36	VSS
A37	SATA_TX-	A38	SATA_RX-
A39	SATA_TX+	A40	SATA_RX+
A41	PE0_TX-	A42	PE0_RX-
A43	PE0_TX+	A44	PE0_RX+
A45	PE0_CLK-	A46	PCIRST-
A47	PE0_CLK+	A48	RESET-
A49	VSS	A50	VSS
A51	LANTX-	A52	LANRX-
A53	LANTX+	A54	LANRX+
A55	VBATT	A56	VCC1.8_OUT
A57	GP80	A58	GP81
A59	GP82	A60	GP83
A61	GP84	A62	GP85
A63	GP86	A64	GP87

Pin#	Single Name	Pin#	Single Name
B1	VCC_IN	B2	VCC_IN
B3	GP70	B4	GP71
B5	GP72	B6	GP73
B7	GP74	B8	GP75
B9	GP76	B10	GP77
B11	GP60	B12	GP61
B13	GP62	B14	GP63
B15	GP64	B16	GP65
B17	GP66	B18	GP67
B19	VSS	B20	VSS
B21	GP50	B22	GP51
B23	GP52	B24	GP53
B25	GP54	B26	GP55
B27	GP56	B28	GP57
B29	GP40	B30	GP41
B31	GP42	B32	GP43
B33	GP44	B34	GP45
B35	GP46	B36	GP47
B37	VSS	B38	VSS
B39	GP30	B40	GP31
B41	GP32	B42	GP33
B43	GP34	B44	GP35
B45	GP36	B46	GP37
B47	GP20	B48	GP21
B49	GP22	B50	GP23
B51	GP24	B52	GP25
B53	GP26	B54	GP27
B55	VSS	B56	VSS
B57	GP10	B58	GP11
B59	GP12	B60	GP13
B61	GP14	B62	GP15
B63	GP16	B64	GP17

2.4.2 J1:JTAG

Pin#	Single Name
1	VCC+
2	GND
3	TCK
4	TDO
5	TDI
6	TMS

2.5 Pin Table List

Catagory	Function	Total pins
SYSTEM	RESET-, PCIRST-	2
CrossBar Interface	GP0[7:0], GP1[7:0], GP2[7:0], GP3[7:0], GP4[7:0], GP5[7:0], GP6[7:0], GP7[7:0], GP8[7:0], GP9[7:0], RSTDRV	81
USB Interface	USBD1-, USBD2-, USBD1+, USBD2+	4
PCIE Bus Interface	PE0_TX-, PE0_RX-, PE0_TX+, PE0_RX+, PE0_CLK-, PE0_CLK+	6
SATA Interface	SATA_TX-, SATA_RX-, SATA_TX+, SATA_RX+	4
Ethernet Interface	LANTX-, LANRX-, LANTX+, LANRX+	4
ADC Interface	ADC_0, ADC_1, ADC_2, ADC_3, ADC_4, ADC_5, ADC_6, ADC_7	8
Battery Power	VBATT	1
ADC Power	AGND, AGND	2
1.8V Power	VCC1.8_OUT	1
5V Power	VCC_IN, VCC_IN	2
Digital Ground	VSS (13 PINs)	13

2.6 Signal Description

System (2pins)

PIN#	Function	TYPE	Description
A48	RESET-	I	System Reset. This pin is used to reset system. When it is asserted low, the board will reset . This pin is low active.
A46	PCIRST-	O	PCI Reset. This pin is used to reset PCI devices. When it is asserted low, all the PCI devices will be reset. This pin is low active,3.3V I/O pad.

CrossBar I/O interface (81 pins)

PIN#	Function	TYPE	Description
A3~A10	GP0[7:0]	I/O	CrossBar Port 0[7:0]. PIn function is select by CrossBar mechanism. This port support CrossBar Bit Mux select by group.
B57~B64	GP1[7:0]	I/O	CrossBar Port 1[7:0]. PIn function is select by CrossBar mechanism. This port support CrossBar Bit Mux select by group.
B47~B54	GP2[7:0]	I/O	CrossBar Port 2[7:0]. PIn function is select by CrossBar mechanism. This port support CrossBar Bit Mux select by group.
B39~B46	GP3[7:0]	I/O	CrossBar Port 3[7:0]. PIn function is select by CrossBar mechanism. This port support CrossBar Bit Mux select by group.
B29~B36	GP4[7:0]	I/O	CrossBar Port 4[7:0]. PIn function is select by CrossBar mechanism. This port support CrossBar Port Mux select by group.
B21~B28	GP5[7:0]	I/O	CrossBar Port 5[7:0]. PIn function is select by CrossBar mechanism. This port support CrossBar Port Mux select by group.
B11~B18	GP6[7:0]	I/O	CrossBar Port 6[7:0]. PIn function is select by CrossBar mechanism. This port support CrossBar Port Mux select by group.
B3~B10	GP7[7:0]	I/O	CrossBar Port 7[7:0]. PIn function is select by CrossBar mechanism. This port support CrossBar Port Mux select by group.
A57~A64	GP8[7:0]	I/O	CrossBar Port 8[7:0]. PIn function is select by CrossBar mechanism. This port support CrossBar Port Mux select by group.
A11~A18	GP9[7:0]	I/O	CrossBar Port 9[7:0]. PIn function is select by CrossBar mechanism. This port support CrossBar Port Mux select by group.
A1	RSTDRV	O	x-ISA Reset. This signal is reset signal for x-ISA bus. This pin is high active, 3.3V I/O pad.

USB interface (4 pins)

PIN#	Function	TYPE	Description
A21	USBD1-	I/O	Universal Serial Bus Controller 0 Port 1. These are the serial data pair for USB Port 1. 15kΩ pull down resistors are connected to DP and DM internally.
A23	USBD1+		
A22	USBD2-	I/O	Universal Serial Bus Controller 0 Port 2. These are the serial data pair for USB Port 2. 15kΩ pull down resistors are connected to DP and DM internally.
A24	USBD2+		

PCIe interface (6 pins)

PIN#	Function	TYPE	Description
A42	PE0_RX-	I	PCI-E Differential serial data input. +: positive; -:negative
A44	PE0_RX+		
A41	PE0_TX-	O	PCI-E Differential serial data output. +: positive; -: negative
A43	PE0_TX+		
A45	PE0_CLK-	O	PCI-E Differential Clock 100MHz from Internal PLL +: positive; -: negative
A47	PE0_CLK+		

SATA interface (4 pins)

PIN#	Function	TYPE	Description
A37	SATA_TX-	O	Serial ATA Device Controller TX Port. These are the serial ATA Transmitter pair for Serial ATA Device.
A39	SATA_TX+		
A38	SATA_RX-	I	Serial ATA Device Controller RX Port. These are the serial ATA Receive pair for Serial ATA Device.
A40	SATA_RX+		

LAN interface (4 pins)

PIN#	Function	TYPE	Description
A51	LANTX-	O	TXN: 10B-T/100BT transmitting output pin/ receiving input pin (negative)
A53	LANTX+	O	TXP: 10B-T/100BT transmitting output pin/ receiving input pin (positive)
A52	LANRX-	I	RXN: 10B-T/100BT receiving input pin/ transmitting output pin (negative)
A54	LANRX+	I	RXP: 10B-T/100BT receiving input pin/ transmitting output pin (positive)

ADC interface (8 pins)

PIN#	Function	TYPE	Description
A27~A34	ADC_[7:0]	I	ADC analog input

ADC power (2 pins)

PIN#	Function	TYPE	Description
A25,A26	AGND	G	Analogue Ground for ADC

Battery power (1 pin)

PIN#	Function	TYPE	Description
A55	VBATT	P	Battery power for RTC (Real Time Clock)

5V power input (2 pins)

PIN#	Function	TYPE	Description
B1,B2	VCC_IN	P	5V Power input.

1.8V power output (1 pin)

PIN#	Function	TYPE	Description
A56	VCC1.8_OUT	P	1.8V Power output. Maximum output: 400mA. For SPI flash disk, LAN transform Or other devices on carrier board which need 1.8V.

Digital ground (13 pins)

PIN#	Function	TYPE	Description
A2,A19,A20,A35, A36,A49,A50,B19 ,B20,B37,B38,B55, B56	VSS	G	Digital Ground

3 Electrical Characteristics

3.1 Pull-up/Pull-down Description

PIN Name	Type	Driving Current	Pull-Up	Pull-Down	Schmitt Trigger	5V I/O Tolerant	Slew Rate	Remark
PORT 0 [0] to PORT 9 [7]	I/O	(Note)	(Note)	(Note)	(Note)	Y	Note 2	Total 80 pins

(Note): Programmable by SocCfgTool software tool (see sample as below)

	Ball No.	Symbol	I/O Type	Description	Slew Rate	Smmitter Trigger	Driving current	I/O Attribute
Port0[0]	C8	NC	I	No function	High	Disable	8mA	Tri-state
Port0[1]	D7	NC	I	No function	Low	Enable	8mA	Tri-state
Port0[2]	B8	NC	I	No function	Low	Disable	16mA	Tri-state
Port0[3]	A8	NC	I	No function	Low	Enable	8mA	Tri-state
Port0[4]	C9	NC	I	No function	High	Disable	8mA	Tri-state
Port0[5]	E9	NC	I	No function	Low	Enable	8mA	Tri-state
Port0[6]	D8	NC	I	No function	Low	Disable	16mA	Tri-state
Port0[7]	E8	NC	I	No function	Low	Enable	8mA	Tri-state

3.2 DC Characteristics

Function	Description	Min.	Typ.	Max.	Unit	Remark
Vil	Input Low Voltage	–	0.0	0.8	V	For CrossBar I/O
Vih	Input High Voltage	2.5	3.3	–	V	For CrossBar I/O
VCC1.8_out	1.8V output	1.7	1.8	1.9	V	
VBATT	Battery power for RTC	2.7	3.0	3.3	V	
VCC_IN	+5V power input	4.9	5.0	5.1	V	

Function	Description	Min.	Max.	Unit	Conditions	Remark
Vol	Output Low Voltage	–	0.4	V	I _{OL} =5mA	For CrossBar I/O
Voh	Output High Voltage	2.4	–	V	I _{OH} =-2mA	For CrossBar I/O
Ibat	Battery standby current for RTC	–	2.5	uA	VBATT = 3.0V	

4 CrossBar I/O Selection

There are 10 ports which contain 8 pins(totally 80pins), and these 80 pins of I/O can freely choose by customer to meet the demand of customer’s project.

4.1 CrossBar I/O overview

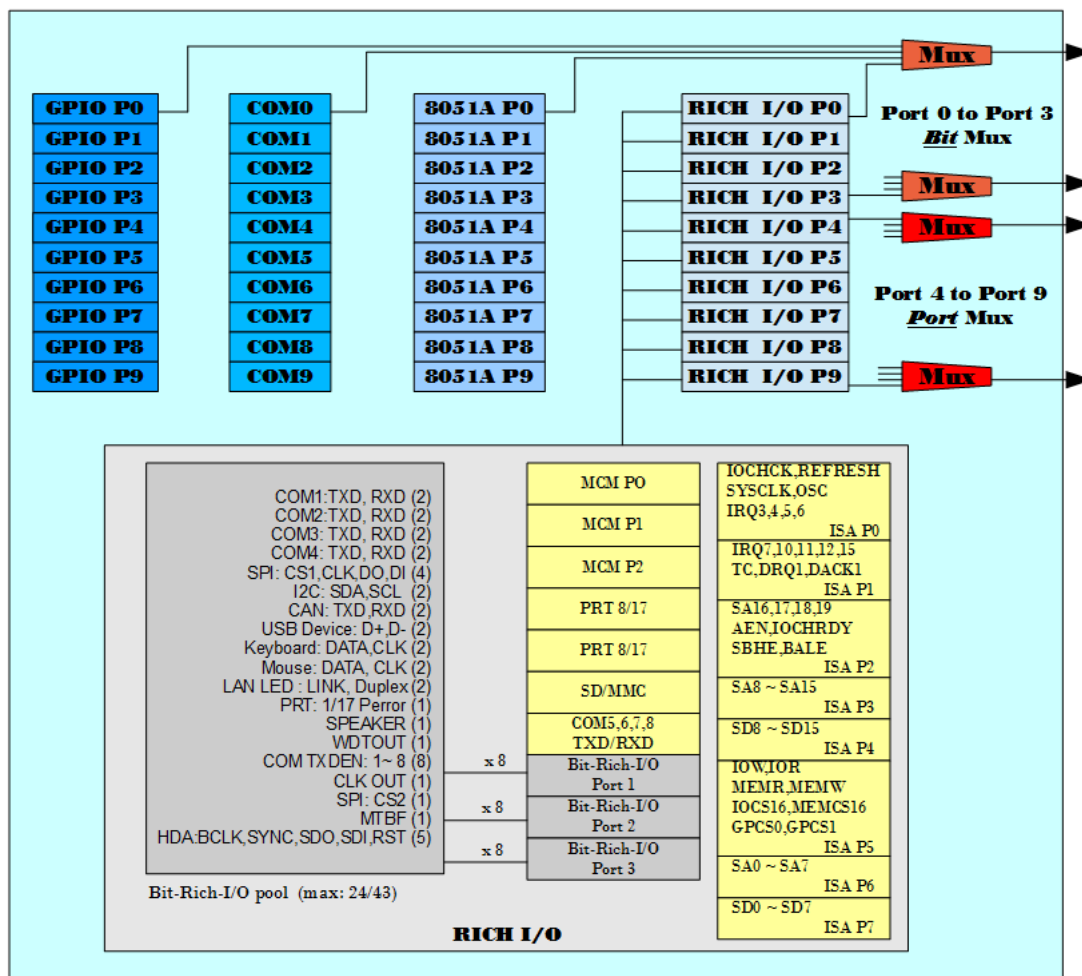

GPIO P0~P9

COM0~9

8051A P0~P9

Above are Port I/O, each port is 8 pins, if you need full-set COM port and 8 bits of GPIO, just simply choice those Port I/O. The 8051A functions are not opened for users because the internal 8051 already simulated 8051 as Keyboard Controller in BIOS.

Port-Rich I/O

All the yellow color blocks above are Port Rich I/O, each port is 8 pins.

Bit-Rich-I/O

All the gray color blocks above are Bit Rich I/O, totally there are 43 pins in Bit-Rich-I/O Pool, you can free choice maximum 24 pins, combine into 3 ports of Bit-Rich I/P Port.

Port 0 to Port 3
Bit Mux

Port 0 to Port 3 are Bit Mux, which means very single bit can be free selectable from Port I/O, Port Rich I/O or Bit Rich I/O.

For example, bit 0.2.4 are Port I/O, bit 1.3.5 are Port Rich I/O and bit 6.7 are Bit Rich I/O.

Port 4 to Port 9
Port Mux

Port 4 to Port 9 are Port Mux, which means the whole port can only select one function. For example, select the whole port for GPIO, not 4 pins for GPIO and other 4 pins for other function.

4.2 Usage of SocCfg Tool

The SocCfgTool is a Vortex86EX SoC configuration tool which you can run on your Windows based PC, you can use SocCfgTool to select the I/O you need, set up the attribute like pull up/down, tri-state or driving current on the I/O pins. Also power-down all the un-used I/O function in order to save the power consumption. After the whole setup in SocCfgTool, it will generate a 240 bytes data files, you can use SPIFLASH (Note) software tool update this 240 bytes file on your VEX-SOM.

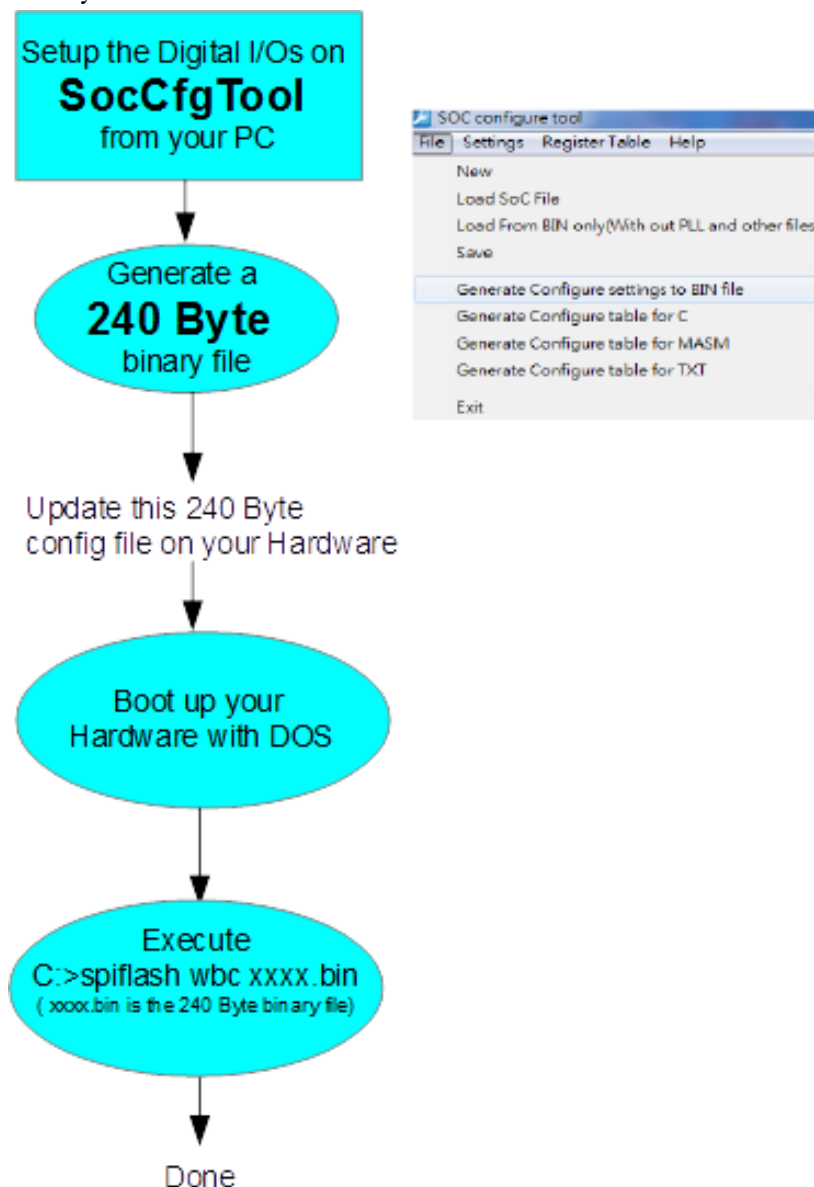

Note: Please get the SocCfgTool and SPIFLASH from your ICOP sales contact.

4.3 Setup the CrossBar I/O

Below are the steps to setup the CrossBar I/O in your VEX-SOM, Write down the your I/O requirement.

- 2, Fill in the VEX-SOM I/O Selection Table. (Note)
- 3, Finish the table and print it out.
- 4, Follow that table to setup in SocCfgTool
- 5, Get the 240 bytes file.
- 6, Update the 240 bytes file on your VEX-SOM.
- 7, Done.

-Please see the video tutorial from

https://www.youtube.com/watch?v=gbLG_BzeuZs.

Note: The VEX-SOM I/O Selection Table is in Appendix A which is in the end of this document.

5. Software Resources

5.1 BIOS

VEX-SOM stored the BIOS in the onboard SPI flash. The default BIOS is CoreBoot BIOS for the users who would like to edit/maintain by himself; user can download the source from www.coreboot.org

ICOP also provide the CoreBoot BIOS service for VEX-SOM customers who need quick boot (0.3 seconds) for their own specific applications. Please check with ICOP Sales for detail.

5.2 Software

The Vortex86EX is a x86 compatible CPU, it supports the legacy operating systems which support 486. Below is the support list.

- DOS
- Linux (Kernel 2.6.24 or later, i486 mode)
- Windows CE 5.0 , CE 6.0 , Compact 7
- Windows XP or XP Embedded (Note)
- VxWorks 5.5 & 6.8
- QNX 6.3.2 (BSP with driver source, users should migrate 6.4 or 6.5 by themsleves).
- FreeBSD, OpenBSD and NetBSD.
- Other real time OS has 486 support, for example RTOS-32.

(Note): Windows XP and XP Embedded are supported, but VEX-SOM has only onboard 128MB DRAM which is too small for Windows XP. Please use other products with more DRAM if you need to run Windows XP or XP Embedded.

6 ADC

6.1 ADC overview

The ADC is an 11-bit, 100kS/s analog-to-digital converter. This ADC adopts successive approximation register (SAR) architecture which using an 9-bit charge scaling sub-DAC for MSB and an 2-bit voltage scaling sub-DAC for LSB. The input range is between 0 and VCCA(3.3V).

It provides an operating voltage range of 1.62V~1.98V.

11-bit, 100kS/s SAR A/D Converter

8-channel input

Input signal range: 0V~VCCA(3.3V)

Operating voltage range: 2.93V~3.63V

6.2 ADC Characteristic

Parameter	Symbol	Description	Min.	Typ.	Max.	Unit
DC ACCURACY						
Resolution			-	11	-	Bits
Integral Nonlinearity	INL	Input is ramp signal	-2	-	2	LSB
Differential Nonlinearity	DNL	Input is ramp signal	-1	-	1	LSB
ANALOG INPUT						
Input Voltage Range		Single-ended inputs	-	VCCA	-	V
Input Capacitance				102.4		pF
CONVERSION RATE						
Input Clock	Fck	Input clock frequency	-	-	1.6	MHz
Sample Frequency	Fs	$F_{ck} = F_s \times (T_c + T_A)$ $F_{ck} = 1.5\text{MHz} / 15$	-	-	100	kHz
Conversion Time	T_c			12		Cycle
Acquisition Time	T_A			4		Cycle
DYNAMIC CHARACTERISTICS (Fs=100kHz)						
Signal-to-Noise plus Distortion Ratio	SNDR	@Fin=50kHz	61.96	-	-	dB
Effective Number of Bit	ENOB	$ENOB = (SNDR - 1.76) / 6.02$	10	-	-	Bit
POWER REQUIREMENT						
Analog Supply Voltage	VCCA		2.97	3.3	3.63	V
Digital Supply Voltage	VCCD		2.97	3.3	3.63	V
Digital Supply Voltage	VCCDC	Clean digital power	2.97	3.3	3.63	V

6.3 ADC Sample code

Please get the ADC sample code from your ICOP sales contact.

7. Evaluation Board

The whole VEX-SOM Evaluation kit including

- VEX-SOM Development Board*1
- MINIPCIE VGA cable*1
- GPIO cable*5
- Mini PCI VGA Board*1
- Mini PCI express to PCI express converter*1
- PRINTET PORT cable*1

PS2 cable*1 The full reference materials including schematic (OrCAD), layout (Allegro), gerber file and layout guide will be provided after purchase the VEX-SOM Evaluation Kit.

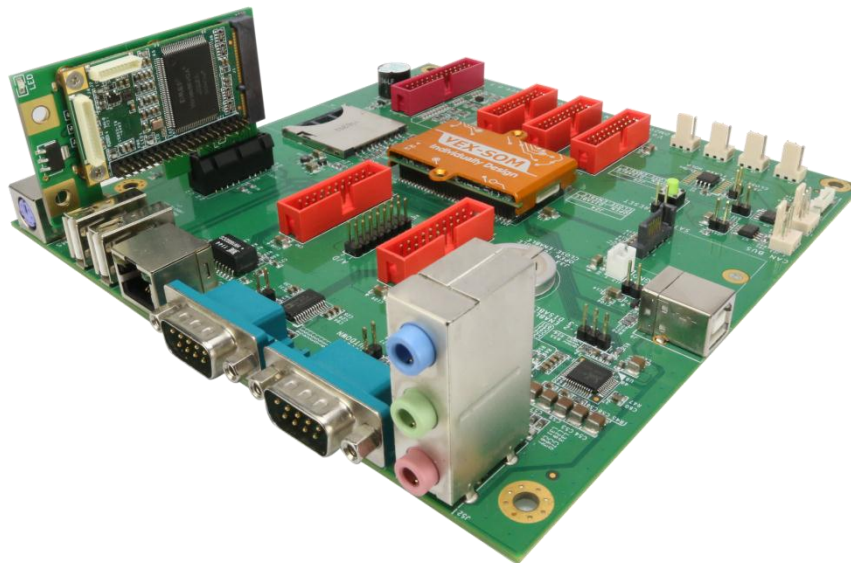

Warranty

This product is warranted to be in good working order for a period of one year (12 months) from the date of purchase. Should this product fail to be in good working order at any time during this period, we will, at our option, replace or repair it without additional charge except as set forth in the following terms. This warranty does not apply to products damaged by misuse, modifications, accident or disaster. Vendor assumes no liability for any damages, lost profits, lost savings or any other incidental or consequential damage resulting from the use, misuse of, originality to use this product. Vendor will not be liable for any claim made by any other related party. Return authorization must be obtained from the vendor before returned merchandise is accepted. Authorization can be obtained by calling or faxing the vendor and requesting a Return Merchandise Authorization (RMA) number. Returned goods should always be accompanied by a clear problem description. Should you have questions about warranty and RMA service, please contact us directly.

ICOP Technology Inc.

Address: No. 15 Wugong 5th Road, Xinzhuang Dist.
New Taipei City, Taiwan (R.O.C.) 24890

TEL: +886-2-8990-1933

FAX: +886-2-8990-2045

Mail: info@icop.com.tw

Website: <http://www.icop.com.tw>

