



**VSX / VDX-DIP-ISA Development Kit
&
VDX-DIP-ISARD CPU Module**
with 5S/ 4 USB/ LAN / 2GPIO/ PWMx24
256MB DDR2 Onboard

User's Manual

(Revision 1.1A)

● Copyright

The information in this manual is subject to change without notice for continuous improvement in the product. All rights are reserved. The manufacturer assumes no responsibility for any inaccuracies that may be contained in this document. And makes no commitment to update or to keep current the information contained in this manual.

No part of this manual may be reproduced, copied, translated or transmitted, in whole or in part, in any form or by any means without the prior written permission of the ICOP Technology Inc.

©Copyright 2008 ICOP Technology Inc.

Manual No. IUMVDX-DIP-ISA000-01 Ver.1.0A ● January, 2010

Manual No. IUMVDX-DIP-ISARD000-01 Ver.1.1A ● September, 2014

● Trademarks Acknowledgment

Vortex86DX™ is the registered trademark of ICOP Technology Inc.

Other brand names or product names appearing in this document are the properties and registered trademarks of their respective owners. All names mentioned herewith are served for identification purpose only.

Table of Contents

Table of Contents	iii
Chapter 1 Introduction.....	1
1.1 Packing List.....	1
1.2 Product Description	2
1.3 Specifications	3
1.4 Board Dimension.....	6
Chapter 2 Installation.....	8
2.1 Board Outline	8
2.2 Connectors & Jumpers Location	11
2.3 Connectors & Jumpers Summary.....	13
2.4 Pin Assignments & Jumper Settings.....	14
2.5 System Mapping.....	25
2.6 Watchdog Timer	28
2.7 GPIO	29
2.8 SPI flash.....	30
2.9 PWM	31
3.0 IDE to SD	32
Chapter 3 Driver Installation.....	33
Appendix	34
A. TCP/IP library for DOS real mode	34
B. VDX-DIP-ISA & VSX-DEV-204-ISA Schematic.....	35
C. BIOS Default Setting.....	36
Warranty.....	37

This page is blank

Chapter 1

Introduction

1.1 Packing List

Product Name	Package
VSX-DEV-204-ISA	<ul style="list-style-type: none">● Vortex86SX/DX CPU Development board x1● RS232 cable x 2● IDE cable (2.0) x 1● IDE cable (2.54) x 1● GPIO cable x 3

Product Name	Package
VDX-DIP-ISARD	<ul style="list-style-type: none">● Embedded Vortex86DX DIP 204pin-ISA CPU Module x1

Product Name	Package
ICOP-2811	<ul style="list-style-type: none">● PC/104 VGA / LCD Module x1
ICOP-0091	<ul style="list-style-type: none">● PC/104 Interface to ISA Bus x1

1.2 Product Description

The VDX-DIP-ISARD family of low-power x86 embedded controller is designed to meet DIP-204pin-ISA specification, and integrated with the following features.

- 800MHz Vortex86DX System-On-Chip
- 256 / 512MB DDR2 system memory
- 4 USB 2.0 (host)
- Up to 5 serial ports (TX RX x1)
- 16-bit GPIO x2
- 2 ISA bus
- 2 watchdog timer
- Enhanced IDE (UltraDMA-100/66/33)
- JTAG interface
- PWM 24~32 channels
- AMI BIOS
- 4MB SPI flash
- Single voltage +5V DC
- Support extended operating temperature range of -20°C to +70°C

VDX-DIP-ISARD is suitable for broad range of data-acquisition, Industrial automation, Process control, Automotive controller, AVL, Intelligent Vehicle management device, Medical device, Human machine interface, Robotics, machinery control And more...application that required small footprint, low-power and low-cost hardware with open industry standard such as DIP-204pin-ISA.

DIP-204pin-ISA module, measured at only 70 x 45mm, is designed particularly as the kernel for the diverse expandable applications. Through 6 rows of 34pin connector, DIP-204pin-ISA module is able to provide multiple functions, such as PCI BUS, RS-232, IDE, LAN, USB and GPIO.

To assist users easily adapt DIP-204pin-ISA Module into their applications, ICOP offers the complete development board for DIP-204pin-ISA Module. ICOP also supplies customers with the referential circuit diagram reducing their time and effort during the development process.

Please visit the website below for further information <http://www.dmp.com.tw/tech/vortex86dx/>

As to the referential circuit drawing, please contact info@icop.com.tw

1.3 Specifications

■ VSX-DEV-204-ISA

Features	VSX / VDX-DEV-204-ISA
Bus Interface	ISA Bus interface
Connectors	<ul style="list-style-type: none"> ● 2.54mm 40-pin header for IDE x1 ● 2.54mm 20-pin header for GPIO x3 ● 2.54mm 10-pin header for RS-230 x2 ● 2.0mm 44-pin header for IDE x1 ● 98-pin slot for ISA x2 ● External RJ-45 connector for Ethernet x1 ● External USB connector x4 ● External 9-pin D-Sub male connector for RS-232 x4 ● External 6-pin Mini DIN connector for Keyboard x1 ● External 6-pin Mini DIN connector for Mouse x1 ● External 3-pin Mini DIN connector for Power x1
Power Requirement	Single Voltage +5V @250mA
Dimension	240 X 160 mm (9.45 x 6.3 inches)
Weight	300g
Operating Temperature	-20°C ~ +70°C -40°C ~ +85°C (Optional)

■ VDX-DIP-ISARD

Features	VDX-DIP-ISARD
CPU	DM&P SoC CPU Vortex86DX- 800MHz Real Time Clock with Lithium Battery Backup
Cache	L1:16K I-Cache, 16K D-Cache L2:128KB Cache
BIOS	AMI BIOS
Bus Interface	ISA interface
System Memory	256 / 512MB DDR2 onboard
Watchdog Timer	Software programmable from 30.5 us to 512 seconds x2 sets(Watchdog 1 fully compatible with M6117D)
I/O Interface	<ul style="list-style-type: none"> ● Enhanced IDE port (UltraDMA-100/66/33) x1 ● RS-232 port x5 (TX RX x1) ● USB port x4 ● 16-bit GPIO port x2
Connectors	<ul style="list-style-type: none"> ● 1.25mm Ø 6-pin Wafer for JTAG x1 ● 2.00 mm Ø 34-pin header for ISA & Multi-I/O x6
Flash Disk Support	<ul style="list-style-type: none"> ● Onboard 4MB SPI Flash Disk (Driver: A)
Power Requirement	Single Voltage +5V @ 320mA
Dimension	70 X 45mm (2.75 x 1.77 inches)
Weight	23g
Operating Temperature	-20°C ~ +70°C -40°C ~ +85°C (Optional)

■ ICOP-2811

Features	ICOP-2811
Chipset	TOPRO TP6508IQ Chip 16-bit ISA bus Panel Data bus: 24-bit Display: CRT and Flat Panel Mono/TFT/DSTN/LCD
BIOS	VGA BIOS
Video Memory	1 MB onboard Resolution up to 1024x768@256 colors
Bus	PC/104 standard compliant
Connectors	<ul style="list-style-type: none"> ● 2.00 mm Ø 44-pin box header for LCD x 1 ● 2.54 mm Ø 10-pin box header for VGA x1 ● External 15-pin D-Sub Female connector for VGA x1
Power Requirement	Single Voltage +5 V@500 mA
Dimensions	90 X 96mm (3.54 x 3.77 inches)
Weight	250g
Operating Temperature	0°C ~ +60°C

Note:

- 1- Please download ICOP-2811 User's manual from
<http://www.icop.com.tw/en/product/Others-ICOP-2811/ICOP-2811.html>
- 2- Please download ICOP-2811 Driver from
http://www.dmp.com.tw/tech/icop_cd/HTML/drv_tp6508.htm

■ VDX-DIP-ISARD

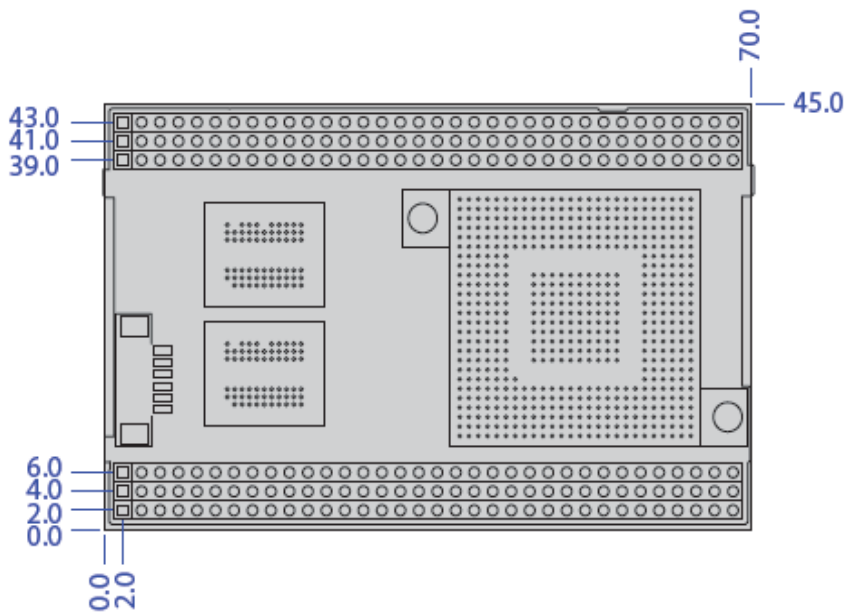

Unit: mm

Chapter 2

Installation

2.1 Board Outline

■ VSX / VDX-DEV-204-ISA

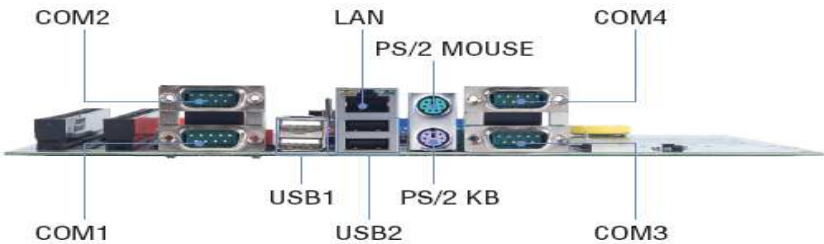
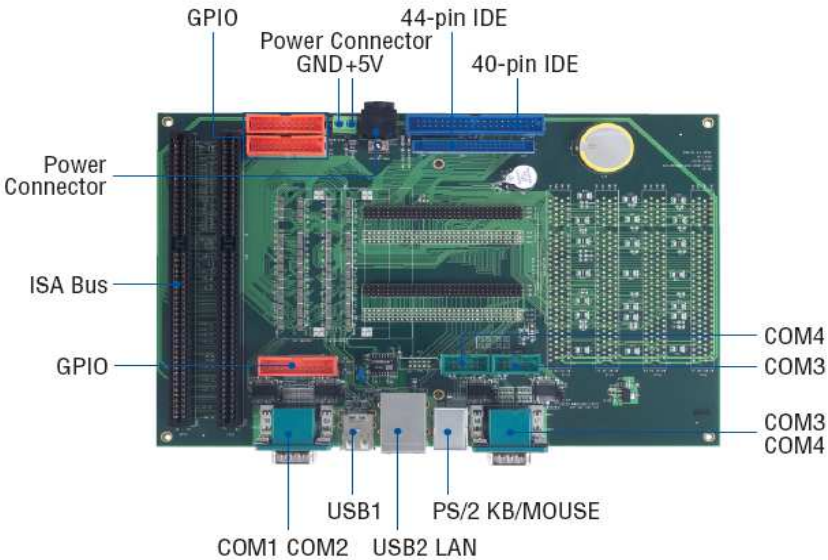

■ VDX-DIP-ISARD

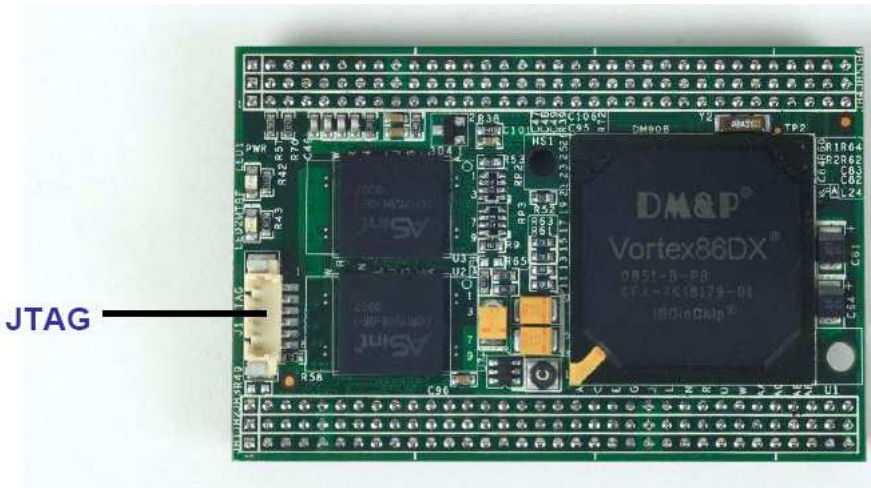

ICOP-2811



VDX-DIP-ISARD Development Kit

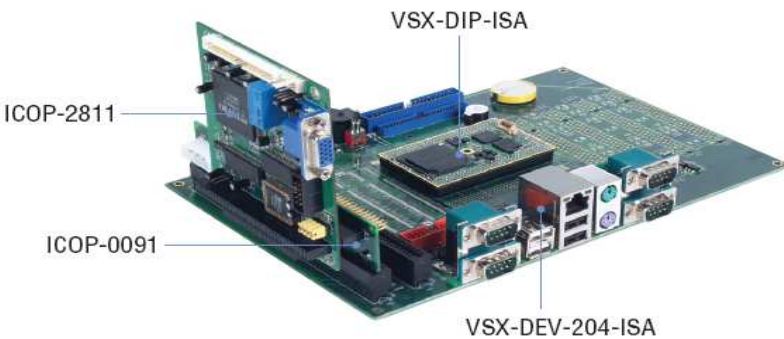

2.2 Connectors & Jumpers Location

Connectors

■ VSX / VDX-DEV-204-ISA

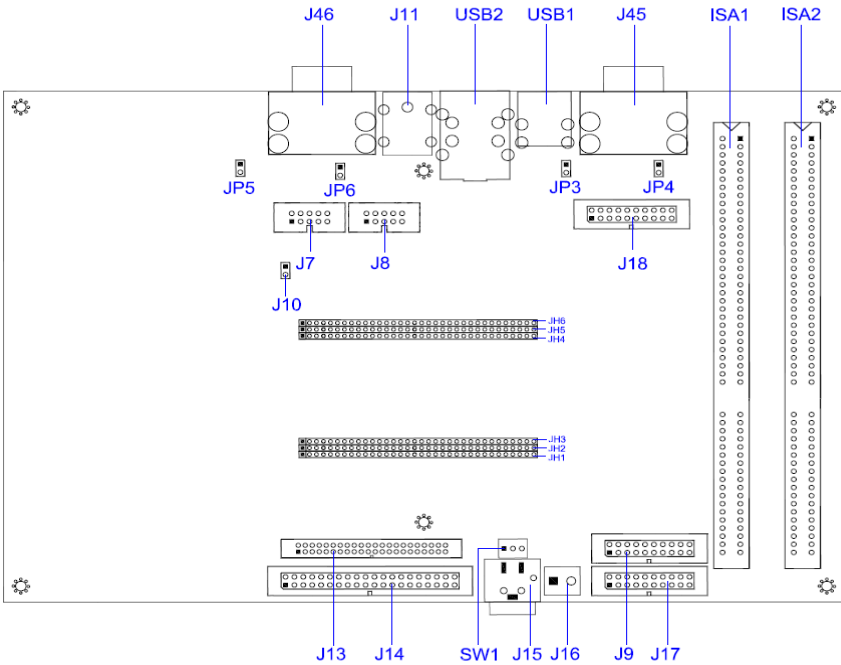

■ VDX-DIP-ISARD

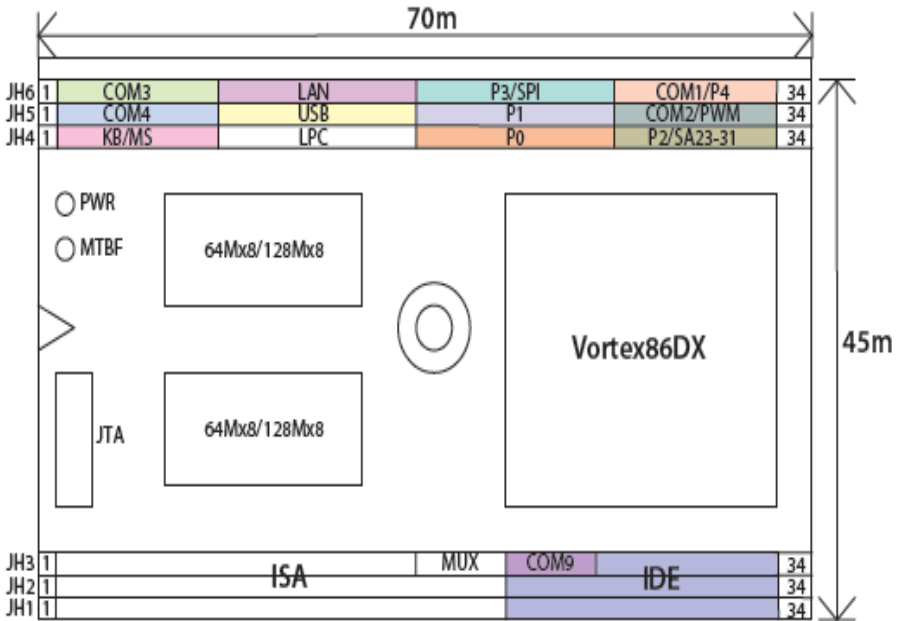

2.3 Connectors & Jumpers Summary

■ VSX / VDX-DEV-204-ISA

Summary Table			
Nbr	Description	Type of Connections	Pin nbrs.
J7	COM3:RS232 / TTL Mode Selector	Box Header, 2.54Ø, 5x2	10-pin
J8	COM4:RS232 / TTL Mode Selector	Box Header, 2.54Ø, 5x2	10-pin
J9	COM1: TTL / GPIO COM2: TTL	Box Header, 2.54Ø, 10x2	10-pin
J10	Reset	Pin Header, 2.54Ø, 1x2	2-pin
J11	PS/2 Keyboard / Mouse	Mini-DIN Female	6-pin
J13	IDE Connector	Box Header, 2.0Ø ,22x2	44-pin
J14	IDE Connector	Box Header, 2.54Ø , 20x2	40-pin
J15	DC +5V Input	Mini-DIN Female	3-pin
J16	Power Connector	Terminal Block 5.0Ø , 2x1	2-pin
J17	GPIO Port 0 / 1/PWMx16	Box Header, 2.54Ø ,10x2	20-pin
J18	GPIO Port 2 / 3/PWMx8	Box Header, 2.54Ø ,10x2	20-pin
J45A/J45B	COM1 / COM2	D-Sub Male	9-pin
J46A/J46B	COM3 / COM4	D-Sub Male	9-pin
USB1	USB 2/ USB 3	USB connector	8-pin
USB2	USB 0/ USB 1	USB connector	8-pin
JH1 JH6	x-ISA & Multi I/O Connector-204 Pin	Pin Header, 2.0Ø 34x6	204-pin
JH13	ISA Slot 1		
JH14	ISA Slot 2		
SP1	BUZZER		
SW1	Power SWITCH		
IDE- LED	IDE Active LED (Green)	LED-SMD	
PWR-LED	Power Active LED (Red)	LED-SMD	

2.4 Pin Assignments & Jumper Settings

■ VSX /VDX-DEV-204-ISA

J7: COM 3: RS232 / TTL Mode Selector

Pin #	Signal Name	Pin #	Signal Name
1	DCD3	2	RXD3
3	TXD3	4	DTR1
5	GND	6	DSR1
7	RTS3	8	CTS1
9	RI3	10	NC

Note: Add 0 ohm on R38 position, COM3 will change to TTL

J8: COM4: RS232 / TTL Mode Selector

Pin #	Signal Name	Pin #	Signal Name
1	DCD4	2	RXD4
3	TXD4	4	DTR4
5	GND	6	DSR4
7	RTS4	8	CTS4
9	RI4	10	NC

Note: Add 0 ohm on R39 position, COM3 will change to TTL

J9: COM1: TTL / GPIO; COM2: TTL

Pin #	Signal Name	Pin #	Signal Name
1	GND	2	VCC
3	DCD1/GP40	4	DCD2
5	TXD1/GP41	6	TXD2
7	RTS1/GP42	8	RTS2
9	RI1/GP43	10	RI2
11	RXD1/GP44	12	RXD2
13	DTR1/GP45	14	DTR2
15	DSR1/GP46	16	DSR2
17	CTS1/GP47	18	CTS2
19	TXDEN1	20	TXDEN2

J10: RESET

Pin #	Signal Name	Pin #	Signal Name
1	Reset	2	GND

J11: PS/2 Keyboard / Mouse

Pin #	Signal Name	Pin #	Signal Name
1	KBDATA	2	NC
3	GND	4	VCC
5	KBCLK	6	NC
7	MSDATA	8	NC
9	GND	10	VCC
11	MSCLK	12	NC
13	GGND	14	GGND
15	GGND	16	GGND
17	GGND		

J13: IDE (44 Pins)

Pin #	Signal Name	Pin #	Signal Name
1	IDERST	2	GND
3	IDED7	4	IDED8
5	IDED6	6	IDED9
7	IDED5	8	IDED10
9	IDED4	10	IDED11
11	IDED3	12	IDED12
13	IDED2	14	IDED13
15	IDED1	16	IDED14
17	IDED0	18	IDED15
19	GND	20	NC
21	IDEREQ	22	GND
23	IDEIOW	24	GND
25	IDEIOR	26	GND
27	ICHRDY	28	GND
29	IDEACK	30	GND
31	IDEINT	32	NC
33	IDESA1	34	IDECBLID
35	IDESA0	36	IDESA2
37	IDECS-0	38	IDECS1
39	IDELED	40	GND
41	VCC	42	VCC
43	GND	44	NC

J14: IDE (40 Pins)

Pin #	Signal Name	Pin #	Signal Name
1	IDERST	2	GND
3	IDED7	4	IDED8
5	IDED6	6	IDED9
7	IDED5	8	IDED10
9	IDED4	10	IDED11
11	IDED3	12	IDED12
13	IDED2	14	IDED13
15	IDED1	16	IDED14
17	IDED0	18	IDED15
19	GND	20	VCC
21	IDEREQ	22	GND
23	IDEIOW	24	GND
25	IDEIOR	26	GND
27	ICHRDY	28	GND
29	IDEACK	30	GND
31	IDEINT	32	NC
33	IDESA1	34	IDECBLID
35	IDESA0	36	IDESA2
37	IDECS0	38	IDECS1
39	IDELED	40	GND

J15: DC 5V INPUT

Pin #	Signal Name
1	+5V
2	GND
3	NC
4	GND

J16: Power Connector (Terminal Block 5.0mm)

Pin #	Signal Name
1	+5V
2	GND

J17: GPIO (Port 0 / Port 1 / PWMx16)

Pin #	Signal Name	Pin #	Signal Name
1	GND	2	VCC
3	GP00	4	GP10
5	GP01	6	GP11
7	GP02	8	GP12
9	GP03	10	GP13
11	GP04	12	GP14
13	GP05	14	GP15
15	GP06	16	GP16
17	GP07	18	GP17
19	VCC	20	GND

J18: GPIO (Port 2 / Port 3 / PWMx8)

Pin #	Signal Name	Pin #	Signal Name
1	GND	2	VCC
3	GP20	4	SPICS / GP30
5	GP21	6	SPICLK / GP31
7	GP22	8	SPID0 / GP32
9	GP23	10	SPIDI / GP33
11	GP24	12	GP34
13	GP25	14	GP35
15	GP26	16	GP36
17	GP27	18	GP37
19	VCC	20	GND

Note:

If you Enable 4M SPI flash Disk in the BIOS setting, you cannot use GP30–GP37 Pins.

JP3: COM1: On/ Off Mode Selector (Open: On, Close: Off)

Pin #	Signal Name	Pin #	Signal Name
1	GND	2	RS232 Disable

JP4: COM2: On/ Off Mode Selector (Open: On, Close: Off)

Pin #	Signal Name	Pin #	Signal Name
1	GND	2	RS232 Disable

JP5: COM3: On/ Off Mode Selector (Open: On, Close: Off)

Pin #	Signal Name	Pin #	Signal Name
1	GND	2	RS232 Disable

JP6: COM4: On/ Off Mode Selector (Open: On, Close: Off)

Pin #	Signal Name	Pin #	Signal Name
1	GND	2	RS232 Disable

J45A: COM 1

Pin #	Signal Name	Pin #	Signal Name
1	DCD1	2	RXD1
3	TXD1	4	DTR1
5	GND	6	DSR1
7	RTS1	8	CTS1
9	RI1		

J45B: COM 2

Pin #	Signal Name	Pin #	Signal Name
1	DCD2	2	RXD2
3	TXD2	4	DTR2
5	GND	6	DSR2
7	RTS2	8	CTS2
9	RI2		

J46A: COM 3

Pin #	Signal Name	Pin #	Signal Name
1	DCD3	2	RXD3
3	TXD3	4	DTR3
5	GND	6	DSR3
7	RTS3	8	CTS3
9	RI3		

J46B: COM 4

Pin #	Signal Name	Pin #	Signal Name
1	DCD4	2	RXD4
3	TXD4	4	DTR4
5	GND	6	DSR4
7	RTS4	8	CTS4
9	RI4		

■ VDX-DIP-ISARD

Summary Table

Nbr	Description	Type of Connections	Pin nbrs.
J1	JTAG	Wafer, 1.25Ø , 6x1	6-pin
JH1 JH6	x-ISA & Multi I/O Connector-204 Pin	Box Header, 2.0Ø 34x6	204-pin
PWR-LED	Power Active LED (Green)	LED-SMD	
MTBF-LED	MTBF-Out (Orange)	LED-SMD	

J1: JTAG

Pin #	Signal Name	Pin #	Signal Name
1	VCC	2	GND
3	TCK	4	TDO
5	TDI	6	TMS

Note: For manufacturer's usage only.

JH1/JH2/JH3/JH4/JH5/JH6: DIP-204pin-ISA Signal Assignment

DIP-204pin-ISA Signal Assignment

Pin	JH1	JH2	JH3	JH4	JH5	JH6
1	VCC-IN	VCC-IN	VCC3-OUT	VBATT	DCD4\	DCD3\
2	SD7	SD8	SA19	PWRGD	RXD4\	RXD3\
3	SD6	SD9	SA18	SPEAKER	TXD4\	TXD3\
4	SD5	SD10	SA17	KBCLK	DTR4\	DTR3\
5	SD4	SD11	SA16	KBDATA	DSR4\	DSR3\
6	SD3	SD12	SA15	MSCCLK	RTS4\	RTS3\
7	SD2	SD13	SA14	MSDATA	CTS4\	CTS3\
8	SD1	SD14	SA13	24MHZ	RI4\	RI3\
9	SD0	SD15	SA12	LINK/ACTIVE	GND	GND
10	RSTDRV	IRQ5	SA11	DUPLEX	LANTX+	LANTX-
11	AEN	IRQ6	SA10	LFRAME-	LANRX+	LANRX-
12	SMEMW	IRQ7	SA9	LDRQ-	LUSBD0+	LUSBD0-
13	SMEMR	IRQ9	SA8	SERIRQ	LUSBD1+	LUSBD1-
14	IOW	IRQ12	SA7	LAD0	LUSBD2+	LUSBD2-
15	IOR	IRQ15	SA6	LAD1	LUSBD3+	LUSBD3-
16	REFRESH	MUX1	SA5	LAD2	GND	GND
17	SYSCLK	MUX2	SA4	GP00	GP10	SPICS
18	OSC	MUX3	SA3	GP01	GP11	SPICLK
19	MEMCS16	MUX4	SA2	GP02	GP12	SPIDO
20	IOCS16	MUX5	SA1	GP03	GP13	SPIDI
21	SBHE	MUX6	SA0	GP04	GP14	GP34
22	ROMCS	GPCS0	IOCHRDY	GP05	GP15	GP35
23	GND	GND	GND	GP06	GP16	GP36
24	IDESA0	IDESA1	TXD9\	GP07	GP17	GP37
25	IDED0	IDED8	RXD9\	LAD3	DCD2\	DCD1\
26	IDED1	IDED9	IDESA2	GP20	RXD2\	RXD1\
27	IDED2	IDED10	IDERST	GP21	TXD2\	TXD1\
28	IDED3	IDED11	IDEINT	GP22	DTR2\	DTR1\
29	IDED4	IDED12	IDEREQ	GP23	DSR2\	DSR1\
30	IDED5	IDED13	IDERDY	GP24	RTS2\	RTS1\
31	IDED6	IDED14	IDEIOW	GP25	CTS2\	CTS1\
32	IDED7	IDED15	IDEACK	GP26	RI2\	RI1\
33	IDECS0	IDECS1	IDECBLID	GP27	TXDEN2	TXDEN1
34	GND	GND	IDEIOR	VCC1.8-OUT	GND	GND

Note:

1. If you Enable 4M SPI flash Disk in the BIOS setting, you cannot use GP30~GP37 Pins.

DIP-204pin-ISA Signal Assignment (Optional)

Pin	JH4	JH5	JH6
1	VBATT	DCD4\	DCD3\
2	PWRGD	RXD4\	RXD3\
3	SPEAKER	TXD4\	TXD3\
4	KBCLK	DTR4\	DTR3\
5	KBDATA	DSR4\	DSR3\
6	MSCLK	RTS4\	RTS3\
7	MSDATA	CTS4\	CTS3\
8	24MHZ	RI4\	RI3\
9	LINK/ACTIVE	GND	GND
10	DUPLEX	LANTX+	LANTX-
11	LFRAME-	LANRX+	LANRX-
12	LDRQ-	LUSBD0+	LUSBD0-
13	SERIRQ	LUSBD1+	LUSBD1-
14	LAD0	LUSBD2+	LUSBD2-
15	LAD1	LUSBD3+	LUSBD3-
16	LAD2	GND	GND
17	GP00	GP10	GP30
18	GP01	GP11	GP31
19	GP02	GP12	GP32
20	GP03	GP13	GP34
21	GP04	GP14	GP34
22	GP05	GP15	GP35
23	GP06	GP16	GP36
24	GP07	GP17	GP37
25	LAD3	PWM0CLK	GP40
26	SA24	PWM2CLK	GP44
27	SA25	PWM0OUT	GP41
28	SA26	PWM2OUT	GP45
29	SA27	PWM0GATE	GP46
30	SA28	PWM1OUT	GP42
31	SA29	PWM1GATE	GP47
32	SA30	PWM1CLK	GP43
33	SA31	PWM2GATE	TXDEN1
34	VCC1.8-OUT	GND	GND

Note:

- Multi-function pins of JH4, JH5, and JH6 are controlled by BIOS setting.

2.5 System Mapping

System Mapping (系統佔用位址說明)

Memory Mapping

Address	Description	Usage
0000:0000-9000:FFFF	System RAM	*
A000:0000-A000:FFFF	EGA/VGA Video Memory	
B000:0000-B000:7FFF	MDA RAM, Hercules graphics display RAM	
B000:8000-B000:FFFF	CGA display RAM	
C000:0000-C000:7FFF	EGA/VGA BIOS ROM	
C000:8000-C000:FFFF	Boot ROM enable.	*
D000:0000-D000:FFFF	Expansion ROM space.	
E000:0000-E000:FFFF	USB Legacy SCSI ROM space.	*
F000:0000-F000:FFFF	Motherboard BIOS	*

I/O Mapping

I/O Address	Owner	Usage
0000h - 000Fh	DMA 8237-1	*
0010h - 0017h	COM 9	*
0018h - 001Fh	Empty	
0020h - 0021h	PIC 8259-1	*
0022h - 0023h	6117D configuration port	*
0024h - 002Dh	Empty	
002Eh - 002Fh	Forward to LPC BUS	*
0030h - 003Fh	Empty	
0040h - 0043h	Timer counter 8254	*
0044h - 0047h	Empty	
0048h - 004Bh	PWM counter 8254	*
004Ch - 004Dh	Empty	
004Eh - 004Fh	Forward to LPC BUS	*
0050h - 005Fh	Empty	
0060h	Keyboard data port	*
0061h	Port B + NMI control port	*
0062h - 0063h	8051 download 4K address counter	*
0064h	Keyboard status port	*

0065h	WatchDog0 reload counter	*
0066h	8051 download 8bit data port	*
0067h	WatchDog1 reload counter	*
0068h - 006Dh	WatchDog1 control register	*
006Eh - 006Fh	Empty	
0070h - 0071h	CMOS RAM port	*
0072h - 0075h	MTBF counter	*
0076h - 0077h	Empty	
0078h - 007Ch	GPIO port 0,1,2,3,4 default setup	*
007Dh - 007Fh	Empty	
0080h - 008Fh	DMA page register	*
0090h - 0091h	Empty	
0092h	System control register	*
0093h - 0097h	Empty	
0098h - 009Ch	GPIO direction control	*
00A0h - 00A1h	PIC 8259-2	*
00A2h - 00BFh	Empty	
00C0h - 00DFh	DMA 8237-2	*
00E0h - 00FFh	Empty	
0100h - 0101h	GPCS1 default setting address	*
0170h - 0177h	IDE1 (IRQ 15)	
01F0h - 01F7h	IDE0 (IRQ 14)	*
0220h - 0227h	COM8 Forward to LPC BUS	
0228h - 022Fh	COM7 Forward to LPC BUS	
0238h - 023Fh	COM6 Forward to LPC BUS	
0278h - 027Fh	Printer port (IRQ 7, DMA 0)	
02E8h - 02EFh	COM4 (IRQ 11)	*
02F8h - 02FFh	COM2 (IRQ 3)	*
0338h - 033Fh	COM5 Forward to LPC BUS	
0376h	IDE1 ATAPI device control write only register	*
03E8h - 03Efh	COM3 (IRQ 10)	*
03F0h - 03F7h	Floppy Disk (IRQ 6, DMA 2)	
03F6h	IDE0 ATAPI device control write only register	*
03F8h - 03FFh	COM1 (IRQ 4)	*
0480h - 048Fh	DMA High page register	*
0490h - 0499h	Instruction counter register	*
04D0h - 04D1h	8259 Edge,/ level control register	*
0CF8h - 0CFFh	PCI configuration port	*
D400h - D4FFh	on board LAN	*
FC00h - FC05h	SPI Flash BIOS control register	*
FC08h - FC0Dh	External SPI BUS control register (output pin configurable GPIO3[0-3])	*

IRQ Mapping		
IRQ#	Description	Usage
IRQ0	System Timer	*
IRQ1	Keyboard Controller	*
IRQ2	Cascade for IRQ8 - 15	
IRQ3	Serial Port 2	*
IRQ4	Serial Port 1	*
IRQ5	USB / Ethernet 10/100M LAN	*
IRQ6	USB	*
IRQ7	Unassigned	
IRQ8	Real Time Clock	*
IRQ9	Serial Port 9	*
IRQ10	Serial Port 3	*
IRQ11	Serial Port 4	*
IRQ12	Mouse	*
IRQ13	Math Coprocessor	*
IRQ14	Hard Disk Controller#1	*
IRQ15	USB	*

DMA Mapping		
DMA#	Description	Usage
DMA0		
DMA1		
DMA2	Floppy Disk Controller	
DMA3		
DMA5		
DMA6		
DMA7		

2.6 Watchdog Timer

There are two watchdog timers in Vortex86SX/DX CPU. One is compatible with M6117D watchdog timer and the other is new. The M6117D compatible watchdog timer is called WDT0 and new one is called WDT1.

We also provide DOS, Linux and WinCE example for your reference. For more technical support, please visit: <http://www.dmp.com.tw/tech> or download the PDF file:

<http://www.dmp.com.tw/tech/vortex86dx/>

2.7 GPIO (General Purpose Input / Output)

40 GPIO pins are provided by the Vortex86SX/DX for general usage in the system. All GPIO pins are independent and can be configured as inputs or outputs, with or without pull-up/pull-down resistors.

We also offer DOS, Linux and WinCE example for your reference. For more technical support, please visit: <http://www.dmp.com.tw/tech> or download the PDF file:

<http://www.dmp.com.tw/tech/vortex86dx/>

2.8 SPI flash (Serial Peripheral Interface)

As SPI Flash (Serial Peripheral Interface) offers many benefits including: reduced controller pin count, smaller and simpler PCBs, reduced switching noise, less power consumption, and lower system cost

Many of users may consider using a formatted SPI flash to boot for the system or emulate SPI flash as Floppy (A: Driver or B: Driver). Then you must know how to set for this condition in CMOS Setup and boot up under DOS 6.22, X-DOS, DR-DOS and Free DOS.

For more technical support, please visit: <http://www.dmp.com.tw/tech> or download the PDF file: <http://www.dmp.com.tw/tech/vortex86dx/>

2.9 PWM (Pulse-width modulation)

Pulse-width modulation (PWM) of a signal or power source involves the modulation of its duty cycle, to either convey information over a communications channel or control the amount of power sent to a load.

The popular applications of pulse width modulation are in speed control of electric motors, volume control of Class D audio amplifiers or brightness control of light sources and many other power electronics applications.

The Vortex86DX SoC integrated 32 channels of PWM interface enabling the Automation, robotic industry to a New Age x86 SoC platform and we also offer the sample code of PWM which will guide the engineer to control the PWM functionality smoothly.

For more inquire of this sample code that please contact our sales team or mail to:

info@icop.com.tw

3.0 IDE to SD (Micro-SD)

Vortex86DX SoC also built-in simulation circuit to adapt SD to IDE in order to allow your system to recognize Micro-SD card as C: or D: Driver

SD-1917: 44 pins IDE to SD Adapter is an ideal solution for industrial PC or embedded system and 44 pins IDE to SD Adapter can be easily installed on all Vortex86DX-63xx CPU boards. You or your customers just do the BIOS setting and use SD-1917 to connect IDE connector of Vortex86DX-63xx directly.

For further inquiries of SD-1917, please contact ICOP sales team or mail to: info@icop.com.tw for your request.

<BIOS setting>

- Get into the BIOS setup Utility
- Choose Primary IDE Pin Select: SD card
- Press “F10” to Save configuration changes and exit setup

SD-1917



SD-1917: <http://www.icop.com.tw/en/product/Accessories-SD-1917/SD-1917.html>

Chapter 4

Driver Installation

VGA

The Vortex86DX processor also uses external Display Card “Volari™ Z9s” which is an ultra low powered graphics chipset with total power consumption at around 1-1.5 W. It is capable in providing VGA display output upto 1600x1200. With DVO interface, developers could easily connect flat Panel to support TFT and LVDS output.

Please download the Driver: http://www.xgitech.com/sd/sd_download.asp

LAN

The Vortex86DX processor also integrated 10/100Mbps Ethernet controller that supports both 10/100BASE-T and allows direct connection to your 10/100Mbps Ethernet based Local Area Network for full interaction with local servers, wide area networks such as the Internet.

The controller supports: Half / Full-Duplex Ethernet function to double channel bandwidth, auto media detection.

Operating system support

The VDX-DIP-ISARD “DIP-204pin- ISA” CPU board provides the VGA and LAN drivers for DOS 6.22 Windows CE 5.0, CE 6.0, Windows 98, Windows XP Professional, Windows Embedded standard (XPE) and Windows 2000 (SP4).

Please get the drivers from the Driver CD which attached with the standard packing of VDX-DIP-ISARD “DIP-204pin- ISA” CPU board or please get it from DMP official website:

<http://www.dmp.com.tw/tech/vortex86dx/>

VDX-DIP-ISARD CPU board also supports most of the popular Linux distributions, for more detail information, please visit DMP official website: <http://www.dmp.com.tw/tech/vortex86dx/>

Appendix

A. TCP/IP library for DOS real mode

DSock is a TCP/IP library for DOS real mode, which is used by RSIP. It provides simple C functions for programmer to write Internet applications. ICOP also provide Internet examples using DSock: BOOTP/DHCP, FTP server, SMTP client/server, HTTP server, TELNET server, Talk client/server, etc.

DSock provides a lot of example source code. Programmer can add Internet functions to their project easily and save development time. With a utility "MakeROM", programmer also can make a ROM image to fit their application, those examples can be seen in the following Application systems: Mity-Mite Serial Server, Web Camera Tiny Server and RSIP Serial Server.

DSock is free for All ICOP products using M6117D/Vortex86/Vortex86SX/Vortex86DX CPU and ICOP also provide the business version of DSock for those customers who are using other x86 CPUs.

If you would like to use DSock or business version of DSock, Please mail to info@icop.com.tw or contact your regional sales.

Please download the trial DSock software and Utilities from our website:
<http://www.dmp.com.tw/tech/dmp-lib/dsock/>

B. VDX-DIP-ISARD & VSX-DEV-204-ISA Schematic

Schematic information can help baseboard designer to optimize exactly how each of these functions implements physically. Designer can place connectors precisely where needed for the application on a baseboard designed to optimally fit a system's packaging.

Please contact or e-mail our regional sales to get VSX-DIP-ISA-V2 、 VDX-DIP-ISARD and VSX-DEV-204-PCI Schematic.

C. BIOS Default setting

If the system cannot be booted after BIOS changes are made, Please follow below procedures in order to restore the CMOS as default setting.

- Press “End” Key, when the power on



- Press to enter the AMI BIOS setup
- Press “F9” to Load Optimized Defaults
- Press “F10” to Save configuration changes and exit setup

Warranty

This product is warranted to be in good working order for a period of one year from the date of purchase. Should this product fail to be in good working order at any time during this period, we will, at our option, replace or repair it at no additional charge except as set forth in the following terms. This warranty does not apply to products damaged by misuse, modifications, accident or disaster. Vendor assumes no liability for any damages, lost profits, lost savings or any other incidental or consequential damage resulting from the use, misuse of, originality to use this product. Vendor will not be liable for any claim made by any other related party. Return authorization must be obtained from the vendor before returned merchandise will be accepted. Authorization can be obtained by calling or faxing the vendor and requesting a Return Merchandise Authorization (RMA) number. Returned goods should always be accompanied by a clear problem description.