

TPC-1782H

17" SXGA TFT LED LCD 4th. Gen. Intel® Core™ i3 Touch Panel Computer

NEW

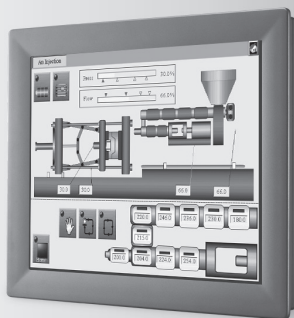

Features

- Industrial 17" SXGA TFT LCD with 50K Lifetime LED Backlight
- Intel 4th Generation Core i3 1.7GHz with 4GB DDR3L SDRAM
- Compact Fanless Embedded System with Al Alloy Front Bezel
- IP65 Approved Front Protection & Panel Mounting
- More Durable 5-wire Resistive Touch Screen
- PCIe 1x and Mini PCIe Expansion Support
- Diverse system I/O and Isolated Digital I/O by iDoor Technology
- Supports Fieldbus Protocol by iDoor Technology
- 3G/GPS/GPRS/WiFi Communication by iDoor Technology
- Supports MRAM by iDoor Technology
- Chassis Grounding Protection
- Supports Advantech SNMP Subagent
- Supports Advantech WISE-PaaS/RMM

Introduction

The TPC-1782H touch panel computer with a 17" SXGA LCD, low power embedded Intel 4th Generation Core i3 1.7GHz processor and 4GB DDR3L SDRAM provides the high computing performance in a compact fanless system. To enhance its durability, the TPC-1782H is designed with IP65 front protection, die-cast Al Alloy front bezel and 5-wire resistive touch. It also includes PCIe slot and Mini-pcie slots to extend the functionality and meet a variety of automation applications needs. Through the Mini-PCIe slot, Advantech iDoor technology can provide more I/O connectors, Isolated Digital I/O, the Fieldbus Protocol, 3G/GPS/GPRS/Wi-Fi Communication and MRAM. A 2nd monitor and speaker can be attached via the integrated HDMI and Audio port.

Specifications

General

- BIOS**: AMI UEFI
- Certification**: BSMI, CCC, CE, FCC Class A, UL
- Cooling System**: Fanless design
- Dimensions (W x H x D)**: 414 x 347.5 x 84 mm (16.3" x 13.68" x 3.31")
- Enclosure**: Front bezel: Die-cast Aluminum alloy
Back housing: PC/ABS Resin
Desktop, Wall or Panel Mount
- Mounting**: Desktop, Wall or Panel Mount
- OS Support**: Microsoft® WES7 32bit/64bit Windows 7 32bit/64bit
Windows Embedded 8.1 Industry Pro 64bit
Windows 7 32bit/64bit/Windows 10 IoT Enterprise LTSC
20W Typical, 60W Max. (Without Add-on card)
- Power Consumption**: 24V_{dc} ± 20%
- Power Input**: 1 ~ 255 sec (system)
- Watchdog Timer**: 6 kg (13.23 lbs)
- Weight (Net)**: 6 kg (13.23 lbs)

System Hardware

- CPU**: Intel 4th Generation Core i3-4010U 1.7GHz
Intel 4th Generation Core i7-4650U 1.7GHz
- Chipset**: Lynx Point-LP
- Memory**: 4GB DDR3L 1600MHz SO-DIMM SDRAM
- LAN**: 10/100/1000 Base-T x 2 (one port supports iAMT)
- Expansion Slots**: Half-size PCIe 1x and Full-size Mini PCI-E
- Storage**: CFast slot x 1
2.5" SATA SSD slot x 1
- I/O**: RS-232 x 1, RS-232/422/485 x 1
USB 3.0 x 2, HDMI 1.4 x 1
Audio Line out x 1, USB 2.0 x 1 (optional)
Audio MIC x 1 (optional)

LCD Display

- Display Type**: SXGA TFT LED LCD
- Display Size**: 17"

- Max. Resolution**: 1280 x 1024
- Max. Colors**: 16.7 M
- Luminance cd/m²**: 350
- Viewing Angle (H/V°)**: 160/140
- Backlight Life**: 50,000 hrs
- Contrast Ratio**: 800:1

Touchscreen

- Lifespan**: 36 million touches at single point
- Light Transmission**: Above 75%
- Resolution**: Linearity
- Type**: 5-wire, analog resistive

Environment

- Humidity**: 10 ~ 95% RH @ 40°C, non-condensing
- Ingress Protection**: Front panel: IP65
- Operating Temperature**: 0 ~ 55°C (32 ~ 131°F)
- Storage Temperature**: -20 ~ 60°C (-4 ~ 140°F)
- Vibration Protection**: With HDD: 1 Grms (5 ~ 500 Hz)
(Operating, random vibration)

Rear View

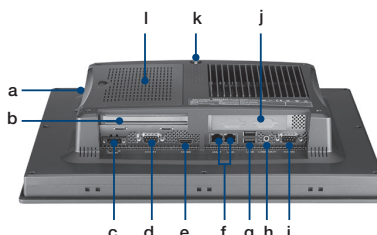

- a. CFast
- b. PCI-E Slot
- c. 24V_{dc} Power
- d. COM (RS-232)
- e. HDMI
- f. LAN
- g. USB3.0
- h. Audio Line Out
- i. COM (RS-232/422/485)
- j. iDoor
- k. SMA Connector for Antenna
- l. 2.5" SATA SSD Slot and Mini-PCIe Slot

Dimensions

Unit: mm

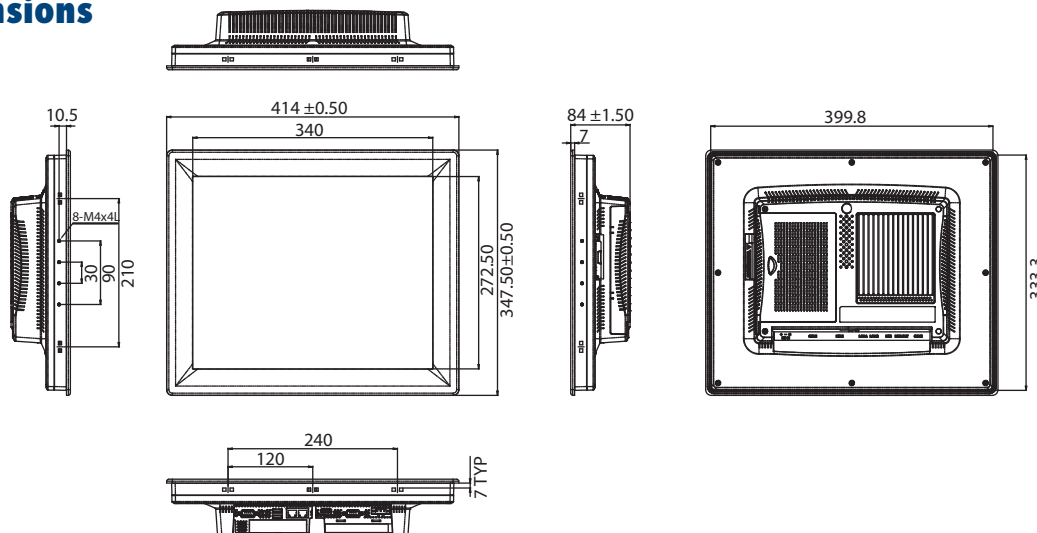

Panel Cut-out Dimensions: 400.8 x 334.3 mm (16.03" x 13.37")

Ordering Information

- **TPC-1782H-433AE** 17" SXGA Panel PC, Intel i3-4010U, 4GB, iDoor, PCIe
- **TPC-1782H-473AE** 17" SXGA Panel PC, Intel i7-4650U, 4GB, iDoor, PCIe

Optional Accessories

- **96PSA-A150W24T2** Adapter 100-240V 150W 24V
- **1702002600** Power Cable US Plug 1.8 M
- **1702002605** Power Cable EU Plug 1.8 M
- **1702031801** Power Cable UK Plug 1.8 M
- **1700000596** Power Cable China/Australia Plug 1.8 M
- **TPC-1000H-WMKE** TPC VESA Mounting Kit from 10" to 17" TPC
- **TPC-1000H-SMKE** TPC Stand kit from 10" to 17" TPC
- **EWM-W151H01E** 802.11bgn RTL8188EE 1T1R, Half-size Mini-PCIe (also need 9656EWMG00E)
- **9656EWMG00E** Half-size miniPCIe to Full-size miniPCIe bracket set
- **1750000318** EMI Antenna 2DBI 2.4GHz SMA CONN for ARK-3384
- **1750003222** 802.11b/g 5dBi Dipole Antenna
- **1750003418** Wireless Antenna AN2400-5901RS R/P SMA.M9dB

Embedded O/S

- **2070013102** TPC-xx82 WS7P x64 MUI Image v4.12 B005

iDoor Modules

- **PCM-24D2R4-AE** 2-Port Isolated RS-422/485 mPCIe, DB9
- **PCM-27D24DI-AE** 24-Channel Isolated Digital I/O w/ counter mPCIe, DB37
- **PCM-26D2CA-AE** 2-Port Isolated CANBus mPCIe, CANOpen, DB9
- **PCM-24R1TP-AE** 1-Port Gigabit Ethernet, Intel® 82574L, mPCIe, RJ45
- **PCM-24S2WF-AE** WiFi 802.11 a/b/g/n 2T2R w/ Bluetooth4.0, Half-size mPCIe, 2-port SMA
- **PCM-26D1DB-MAE** 1-Port Hilscher netX100 FieldBus mPCIe, PROFIBUS, DB9, Master
- **PCM-26R2PN-MAE** 2-Port Hilscher netX100 FieldBus mPCIe, PROFINET, RJ45, Master

- **PCM-26R2EC-MAE** 2-Port Hilscher netX100 FieldBus mPCIe, EtherCAT, RJ45, Master
- **PCM-26R2EI-MAE** 2-Port Hilscher netX100 FieldBus mPCIe, EtherNet/IP, RJ45, Master
- **PCM-26R2S3-MAE** 2-Port Hilscher netX100 FieldBus mPCIe, Sercos III, RJ45, Master

Application Software

<p>WebAccess/SCADA</p>	<p>Advantech WebAccess is a 100% web based SCADA (Supervisory Control And Data Acquisition) software and it acts as an IIoT Platform providing open interfaces for partners to develop IoT applications for different vertical markets. In addition to traditional SCADA functions, WebAccess has an intelligent Dashboard, to provide users with cross-platform, cross-browser data analysis and user interface using HTML5 technology. As well as the built-in widgets, WebAccess also provides Widget Builder to allow customers to build their own.</p>
<p>WebAccess/HMI</p>	<p>WebAccess/HMI is Human Machine Interface (HMI) software based on Microsoft's Windows operating system. It utilizes a PC's ample resources, ie speed, storage, multimedia, peripheral devices, and large screen to produce a complex human-machine interface. WebAccess/HM with its communication and monitoring ability supports more than 350 PLC communication protocols and a wide choice of screen design objects, to satisfy multiple integrations of factory automation and all-round human-machine interface operation and monitoring requirements.</p>
<p> CODESYS</p>	<p>The Codesys application-ready-package offering which includes PC-based Panel Controller with multi-touch panel, high performance Intel Core-i multi-core processor, SSD, 2MB MRAM, Microsoft Windows embedded 7 Pro and CODESYS Control Runtime & Visualization. This allows users to easily achieve an open control solution, the PC-based real-time control system, enabling real-time PLC or PLC/Softmotion control with flexible Fieldbus options such as PROFINET, EtherCAT, EtherNet/IP, CANopen, Modbus TCP/RTU and providing the on-site visualized HMI operation. The software/hardware flexibility and stability of PC-based Cabinet Controller is able to fulfill various control applications in vertical industries.</p>