

# DIN-825-GP4 User Guide

## Notice

The **DIN-825-GP4** is used for wiring between **Any** well-known Servo driver / stepper with Pulse and Voltage input driver and **ADLINK PCI-8254, PCI-8258, AMP-204C and AMP-208C** controllers **ONLY**. Never use this terminal board with other motion control cards.

P/N: 50-11247-1000 Rev.3.0

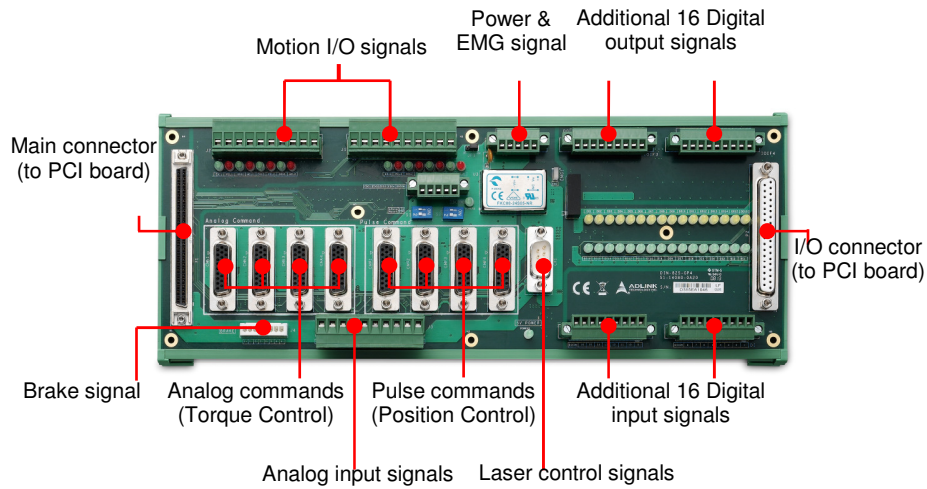

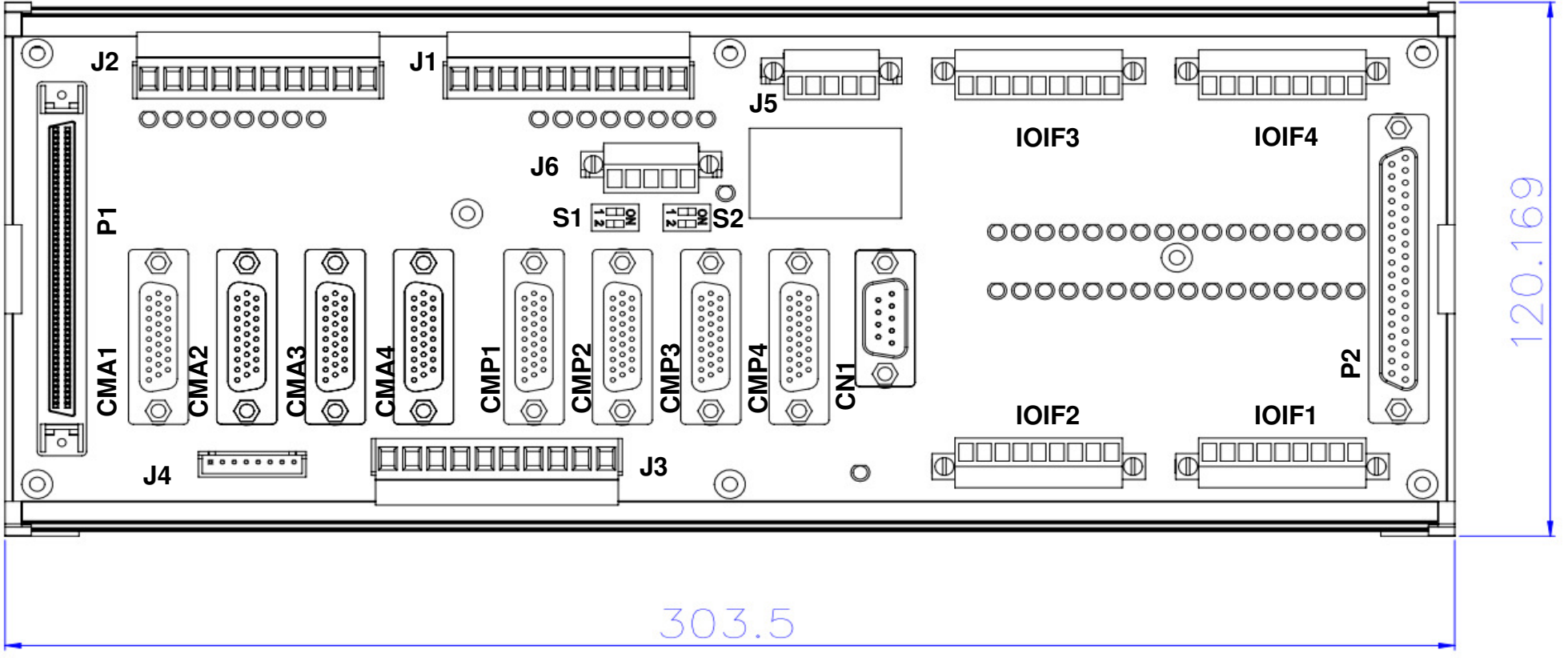

1. **P1**: One SCSI 100-PINS connector which is main connector to command and feedback whole motion control signals.
2. **CMA1-4**: Four 26-PINS connectors to connect servo drives with Voltage command which include Mitsubishi J3/J4 series, Yaskawa Sigma II, III & V series, Panasonic MINAS A4/A5 series and any others servo driver by general purposed cable with one-side OPEN design.
3. **CMP1-4**: Four 26-PINS connectors to connect specific servo / stepper drives with Pulse-train command which include Mitsubishi J3/J4 series, Yaskawa Sigma II, III & V series, Panasonic MINAS A4/A5 series, Delta A2 series and any others servo / stepper driver by general purposed cable with one-side OPEN design.
4. **J1-J3**: Three 10-PINS screw type connectors to connect all analog input signals, trigger output signals and motion I/Os which include EL+/EL-/ORG and universal IO.
5. **J4**: Brake signals connector
6. **J5**: Main power & EMG connector
7. **J6**: 4-CH isolated digital output connector
8. **P2**: One DSUB 37-PINS connector which connect onboard 16-CH TTL digital input and 16-CH TTL digital output
9. **IOIF1-IOIF4**: Four 9-PINS screw connectors to connect total 16-CH isolated digital input and 16-CH digital output.
10. **CN1**: Laser control signals connector

● PIN Assignments:

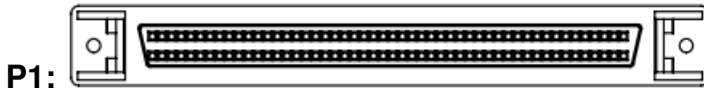

No.	Name	I/O	Function of Axis	No.	Name	I/O	Function of Axis
1	DGND	--	Digital ground	51	IEMG	I	Emergency stop input
2	DGND	--	Digital ground	52	Rsv.	--	Reserved
3	AGND	--	Analog ground	53	AGND	--	Analog ground
4	AGND	--	Analog ground	54	AGND	--	Analog ground
5	AOUT1+	O	Analog output (+),(1)	55	AOUT3+	O	Analog output (+),(3)
6	AOUT1-	O	Analog output (-),(1)	56	AOUT3-	O	Analog output (-),(3)
7	AOUT2+	O	Analog output (+),(2)	57	AOUT4+	O	Analog output (+),(4)
8	AOUT2-	O	Analog output (-),(2)	58	AOUT4-	O	Analog output (-),(4)
9	AIN1	I	Analog input, (1)	59	AIN3	I	Analog input, (3)
10	AIN2	I	Analog input, (2)	60	AIN4	I	Analog input, (4)
11	Rsv.	--	Reserved	61	DGND	--	Digital ground
12	Rsv.	--	Reserved	62	DGND	--	Digital ground
13	OUT1+	O	Pulse output (+), (1)	63	OUT3+	O	Pulse output (+), (3)
14	OUT1-	O	Pulse output (-), (1)	64	OUT3-	O	Pulse output (-), (3)
15	DIR1+	O	Direction output (+), (1)	65	DIR3+	O	Direction output (+), (3)
16	DIR1-	O	Direction output (-), (1)	66	DIR3-	O	Direction output (-), (3)
17	OUT2+	O	Pulse output (+), (2)	67	OUT4+	O	Pulse output (+), (4)
18	OUT2-	O	Pulse output (-), (2)	68	OUT4-	O	Pulse output (-), (4)
19	DIR2+	O	Direction output (+), (2)	69	DIR4+	O	Direction output (+), (4)
20	DIR2-	O	Direction output (-), (2)	70	DIR4-	O	Direction output (-), (4)
21	TRG1+	O	Trigger output (+), (1)	71	TRG2+	O	Trigger output (+), (2)
22	TRG1-	O	Trigger output (-), (1)	72	TRG2-	O	Trigger output (-), (2)
23	EA1+	I	Encoder A-phase (+),(1)	73	EA3+	I	Encoder A-phase (+),(3)
24	EA1-	I	Encoder A-phase (-),(1)	74	EA3-	I	Encoder A-phase (-),(3)
25	EB1+	I	Encoder B-phase (+),(1)	75	EB3+	I	Encoder B-phase (+),(3)
26	EB1-	I	Encoder B-phase (-),(1)	76	EB3-	I	Encoder B-phase (-),(3)
27	EZ1+	I	Encoder Z-phase (+),(1)	77	EZ3+	I	Encoder Z-phase (+),(3)
28	EZ1-	I	Encoder Z-phase (-),(1)	78	EZ3-	I	Encoder Z-phase (-),(3)
29	EA2+	I	Encoder A-phase (+),(2)	79	EA4+	I	Encoder A-phase (+),(4)
30	EA2-	I	Encoder A-phase (-),(2)	80	EA4-	I	Encoder A-phase (-),(4)
31	EB2+	I	Encoder B-phase (+),(2)	81	EB4+	I	Encoder B-phase (+),(4)
32	EB2-	I	Encoder B-phase (-),(2)	82	EB4-	I	Encoder B-phase (-),(4)
33	EZ2+	I	Encoder Z-phase (+),(2)	83	EZ4+	I	Encoder Z-phase (+),(4)
34	EZ2-	I	Encoder Z-phase (-),(2)	84	EZ4-	I	Encoder Z-phase (-),(4)
35	ALM1	I	Servo alarm,(1)	85	ALM3	I	Servo alarm,(3)
36	ORG1	I	Home limit, (1)	86	ORG3	I	Home limit, (3)

37	SVON1	O	Servo-ON, (1)	87	SVON3	O	Servo-ON, (3)
38	PEL1	I	Positive limit, (1)	88	PEL3	I	Positive limit, (3)
39	ZSP1	I	Zero Speed (1)	89	ZSP3	I	Zero Speed (3)
40	MEL1	I	Negative limit, (1)	90	MEL3	I	Negative limit, (3)
41	ALM2	I	Servo alarm,(2)	91	ALM4	I	Servo alarm,(4)
42	ORG2	I	Home limit, (2)	92	ORG4	I	Home limit, (4)
43	SVON2	O	Servo-ON, (2)	93	SVON4	O	Servo-ON, (4)
44	PEL2	I	Positive limit, (2)	94	PEL4	I	Positive limit, (4)
45	ZSP2	I	Zero Speed (2)	95	ZSP4	I	Zero Speed (4)
46	MEL2	I	Negative limit, (2)	96	MEL4	I	Negative limit, (4)
47	EDO1	O	Digital Output, (1)	97	EDO3	O	Digital Output, (3)
48	EDI1	I	Digital Input, (1)	98	EDI3	I	Digital Input, (3)
49	EDO2	O	Digital Output, (2)	99	EDO4	O	Digital Output, (4)
50	EDI2	I	Digital Input, (2)	100	EDI4	I	Digital Input, (4)

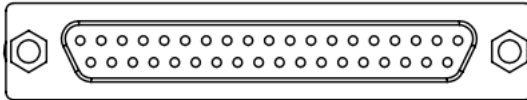

P2:

No.	Name	I/O	Function of Axis	No.	Name	I/O	Function of Axis
1	Rsv.	--	Reserved	20	VDD	--	+5V Power Supply
2	TDI1	I	TTL input, (1)	21	TDO1	O	TTL output, (1)
3	TDI2	I	TTL input, (2)	22	TDO2	O	TTL output, (2)
4	TDI3	I	TTL input, (3)	23	TDO3	O	TTL output, (3)
5	TDI4	I	TTL input, (4)	24	TDO4	O	TTL output, (4)
6	TDI5	I	TTL input, (5)	25	TDO5	O	TTL output, (5)
7	TDI6	I	TTL input, (6)	26	TDO6	O	TTL output, (6)
8	TDI7	I	TTL input, (7)	27	TDO7	O	TTL output, (7)
9	TDI8	I	TTL input, (8)	28	TDO8	O	TTL output, (8)
10	TDI9	I	TTL input, (9)	29	TDO9	O	TTL output, (9)
11	TDI10	I	TTL input, (10)	30	TDO10	O	TTL output, (10)
12	TDI11	I	TTL input, (11)	31	TDO11	O	TTL output, (11)
13	TDI12	I	TTL input, (12)	32	TDO12	O	TTL output, (12)
14	TDI13	I	TTL input, (13)	33	TDO13	O	TTL output, (13)
15	TDI14	I	TTL input, (14)	34	TDO14	O	TTL output, (14)
16	TDI15	I	TTL input, (15)	35	TDO15	O	TTL output, (15)
17	TDI16	I	TTL input, (16)	36	TDO16	O	TTL output, (16)
18	DGND	--	Digital ground	37	DGND	--	Digital ground
19	VDD	I	+5V power supply input	--	--	--	--

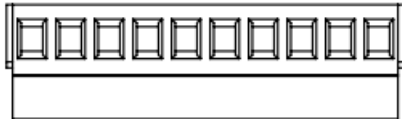
**J1:**

No.	Name	I/O	Function	No.	Name	I/O	Function
1	DICOM	--	Digital input common	6	EDI4	I	Isolated digital input, (4)
2	EDI3	I	Isolated digital input, (3)	7	PEL4	I	Positive limit, (4)
3	PEL3	I	Positive limit, (3)	8	ORG4	I	Home limit, (4)
4	ORG3	I	Home limit, (3)	9	MEL4	I	Negative limit, (4)
5	MEL3	I	Negative limit, (3)	10	DOCOM	--	Digital output common



**DICOM:** This signal shall be connected to I24V.

**DOCOM:** This signal shall be connected to IGND.

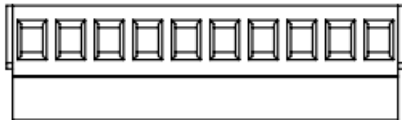
**Note****J2:**

No.	Name	I/O	Function	No.	Name	I/O	Function
1	DICOM	--	Digital input common	6	EDI2	I	Isolated digital input, (2)
2	EDI1	I	Isolated digital input, (1)	7	PEL2	I	Positive limit, (2)
3	PEL1	I	Positive limit, (1)	8	ORG2	I	Home limit, (2)
4	ORG1	I	Home limit, (1)	9	MEL2	I	Negative limit, (2)
5	MEL1	I	Negative limit, (1)	10	DOCOM	--	Digital output common



**DICOM:** This signal shall be connected to I24V.

**DOCOM:** This signal shall be connected to IGND.

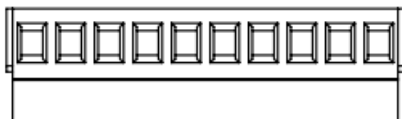
**Note****J3:**

No.	Name	I/O	Function	No.	Name	I/O	Function
1	DGND	-	Isolated digital ground	6	AGND	-	Analog ground
2	TRG2-	O	Trigger output (-), (2)	7	AI4	I	Analog input, (4)
3	TRG2+	O	Trigger output (+), (2)	8	AI3	I	Analog input, (3)
4	TRG1-	O	Trigger output (-), (1)	9	AI2	I	Analog input, (2)
5	TRG1+	O	Trigger output (+), (1)	10	AI1	I	Analog input, (1)

**J4: Brake Connector**

No.	Name	I/O	Function	No.	Name	I/O	Function
1	1+	O	Brake signal (+), (1)	6	3+	O	Brake signal (+), (3)
2	1-	O	Brake signal (-), (1)	7	3-	O	Brake signal (-), (3)
3	2+	O	Brake signal (+), (2)	8	4+	O	Brake signal (+), (4)
4	2-	O	Brake signal (-), (2)	9	4-	O	Brake signal (-), (4)

**J5:**

No.	Name	I/O	Function	No.	Name	I/O	Function
1	I24V	--	Ext. power supply, +24V	4	DOCOM	--	Digital output common
2	IGND	--	Ext. power ground	5	EEMG	I	Ext. Emergency signal
3	DICOM	--	Digital input common	--	--	--	--



**DICOM:** This signal shall be connected to I24V.

**DOCOM:** This signal shall be connected to IGND.

**Note****J6:**

No.	Name	I/O	Function	No.	Name	I/O	Function
1	EDO1	O	Digital output, (1)	4	EDO4	O	Digital output, (4)
2	EDO2	O	Digital output, (2)	5	DOCOM	--	Digital output common
3	EDO3	O	Digital output, (3)	--	--	--	--



1. **DOCOM:** This signal shall be connected to IGND.

2. **EDO** is for the device whose power system is I24V and IGND.

**Note**

## IOIF1:



No.	Name	I/O	Function	No.	Name	I/O	Function
1	DI1	I	Additional isolated digital input, (1)	6	DI6	I	Additional isolated digital input, (6)
2	DI2	I	Additional isolated digital input, (2)	7	DI7	I	Additional isolated digital input, (7)
3	DI3	I	Additional isolated digital input, (3)	8	DI8	I	Additional isolated digital input, (8)
4	DI4	I	Additional isolated digital input, (4)	9	DIO24V	--	Ext. power supply, +24V
5	DI5	I	Additional isolated digital input, (5)	--	--	--	--

## IOIF2:

No.	Name	I/O	Function	No.	Name	I/O	Function
1	DI9	I	Additional isolated digital input, (9)	6	DI14	I	Additional isolated digital input, (14)
2	DI10	I	Additional isolated digital input, (10)	7	DI15	I	Additional isolated digital input, (15)
3	DI11	I	Additional isolated digital input, (11)	8	DI16	I	Additional isolated digital input, (16)
4	DI12	I	Additional isolated digital input, (12)	9	DIO24V	--	Ext. power supply, +24V
5	DI13	I	Additional isolated digital input, (13)	--	--	--	--

## IOIF3:

No.	Name	I/O	Function	No.	Name	I/O	Function
1	※DO1	O	Additional isolated digital output, (1)	6	※DO6	O	Additional isolated digital output, (6)
2	※DO2	O	Additional isolated digital output, (2)	7	※DO7	O	Additional isolated digital output, (7)
3	※DO3	O	Additional isolated digital output, (3)	8	※DO8	O	Additional isolated digital output, (8)
4	※DO4	O	Additional isolated digital output, (4)	9	DIOGND	--	Ext. power ground
5	※DO5	O	Additional isolated digital output, (5)	--	--	--	--

## IOIF4:

No.	Name	I/O	Function	No.	Name	I/O	Function
1	※DO9	O	Additional isolated digital output, (9)	6	※DO14	O	Additional isolated digital output, (14)
2	※DO10	O	Additional isolated digital output, (10)	7	※DO15	O	Additional isolated digital output, (15)
3	※DO11	O	Additional isolated digital output, (11)	8	※DO16	O	Additional isolated digital output, (16)
4	※DO12	O	Additional isolated digital output, (12)	9	DIOGND	--	Ext. power ground
5	※DO13	O	Additional isolated digital output, (13)	--	--	--	--



1. ※means the channel is able to sink up to 250mA
2. When using DO, DIO24V must be connected to 24 volt.

## Note

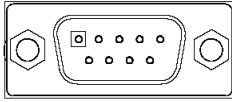
**CN1:**

No.	Name	I/O	Function	No.	Name	I/O	Function
1	EDO4	O	Digital output (4)	6	EDO4-	O	Digital output (-), (4)
2	TRG1+	O	Trigger output (+), (1)	7	TRG1-	O	Trigger output (-), (1)
3	TRG2+	O	Trigger output (+), (2)	8	TRG2-	O	Trigger output (-), (2)
4	--	--	--	9	DGND	--	Digital ground
5	--	--	--				

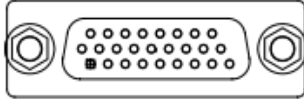
**CMA1~CMA4:**

No.	Name	I/O	Function	No.	Name	I/O	Function	No.	Name	I/O	Function
				10	ALM_RST / DO	O	Reset driver signal / Digital output signal				
1	SVON	O	Servo On signal					19	EMG	I	Emergency signal
				11	ALM	I	Servo alarm signal				
2	ZSP	I	Zero speed signal					20	IGND	--	Ext. power ground
				12	I24V	--	Ext. power supply, +24V				
3	Rsv.	--	Reserved					21	IGND	--	Ext. power ground
				13	IGND	--	Ext. power ground				
4	Rsv.	--	Reserved.					22	IGND	--	Ext. power ground
				14	BRAKE-	O	Brake signal(-)				
5	AOUT-	O	Analog command output (-)					23	Rsv.	--	Reserved
				15	AGND	--	Analog ground				
6	AOUT+	O	Analog command output (+)					24	Rsv.	--	Reserved
				16	EB-	I	Encoder B-phase(-)				
7	EA-	I	Encoder A-phase(-)					25	EZ-	I	Encoder Z-phase(-)
				17	EB+	I	Encoder B-phase(+)				
8	EA+	I	Encoder A-phase(+)					26	EZ+	I	Encoder Z-phase(+)
				18	AGND	--	Analog ground				
9	BRAKE+	O	Brake signal(+)								



**ALM\_RST / DO:** This signal can be switched to reset servo driver while the alarm was occurring or be general digital output by DIP switch-**S1**, **S2** selecting.

**Note**



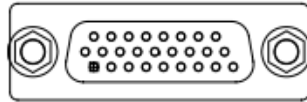

**CMP1~CMP4:**

No.	Name	I/O	Function	No.	Name	I/O	Function	No.	Name	I/O	Function
				10	ALM_RST / DO	O	Reset driver signal / Digital output signal				
1	SVON	O	Servo On signal					19	EMG	I	Emergency signal
				11	ALM	I	Servo alarm signal				
2	INP	I	In-position signal					20	IGND	--	Ext. power ground
				12	I24V	--	Ext. power supply, +24V				
3	ERC	--	Dev. ctr, clr. signal					21	IGND	--	Ext. power ground
				13	IGND	--	Ext. power ground				
4	RDY	--	Servo ready signal					22	IGND	--	Ext. power ground
				14	BRAKE-	O	Brake signal(-)				
5	OUT-	O	Pulse signal (-)					23	DIR-	O	Dir. Signal(-)
				15	IGND	--	Ext. power ground				
6	OUT+	O	Pulse signal (+)					24	DIR+	O	Dir. Signal(+)
				16	EB-	I	Encoder B-phase(-)				
7	EA-	I	Encoder A-phase(-)					25	EZ-	I	Encoder Z-phase(-)
				17	EB+	I	Encoder B-phase(+)				
8	EA+	I	Encoder A-phase(+)					26	EZ+	I	Encoder Z-phase(+)
				18	IGND	--	Ext. power ground				
9	BRAKE+	O	Brake signal(+)								



**ALM\_RST / DO:** This signal can be switched to reset servo driver while the alarm was occurring or be general digital output by DIP switch-S1, S2 selecting.

**Note**

**S1, S2: Enable/Disable DO to reset servo driver**

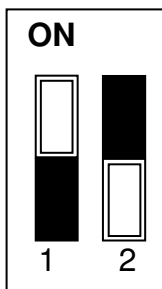

**ON = Reset servo driver**

**S1**    1        2  
          ON        ON        Reset servo driver 1  
                     ON        Reset servo driver 2

**S2**    1        2  
          ON        ON        Reset servo driver 3  
                     ON        Reset servo driver 4

**OFF is default**

There are 4 alarm reset signal on the DIN-825-GP4. The alarm reset signals are programmed by J6.DO1~J6.DO4 signals. The switches are switched 'ON' and then pass DO1 signals to reset servo. (CMA1.10~CMA4.10, CMP1.10~CMP4.10)

## ● Wiring Examples: Signal Connections of Interface Circuit

### 1. EMG: Emergency stop input

There is emergency stop input pin for this module. When EMG is active, all the motion pulse output command or motion analog command will be rejected until the EMG is inactive. The emergency stop switch should have a contact capacity of +24V @ 6mA minimum. 'B-type' (normal closed) contact switches can be used. The type of switch can be configured by software.

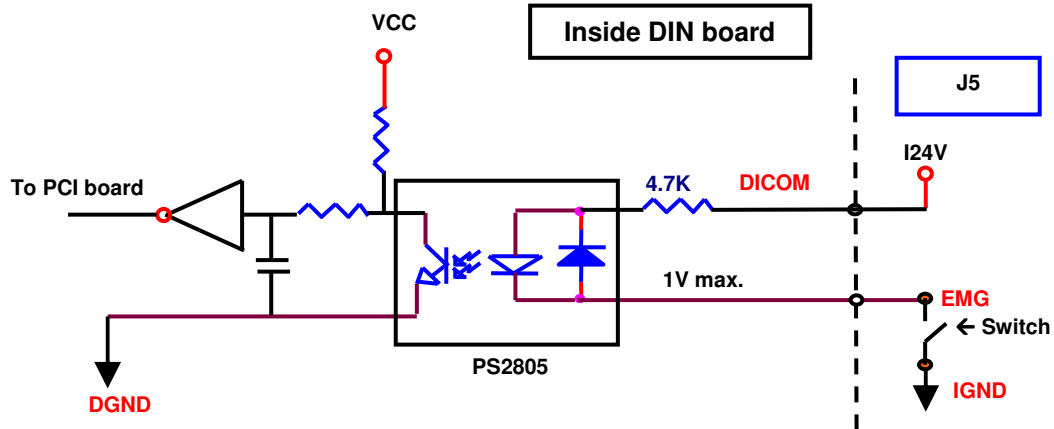

### 2. MEL, PEL, ORG, DI: Negative/Positive limit switch, Home limit switch, General purposed digital input

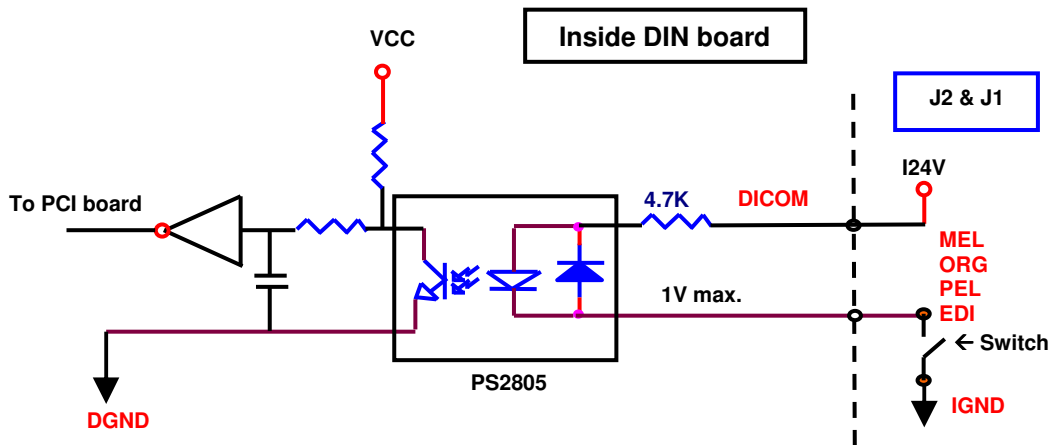

### 3. ALM, INP/ZSP:

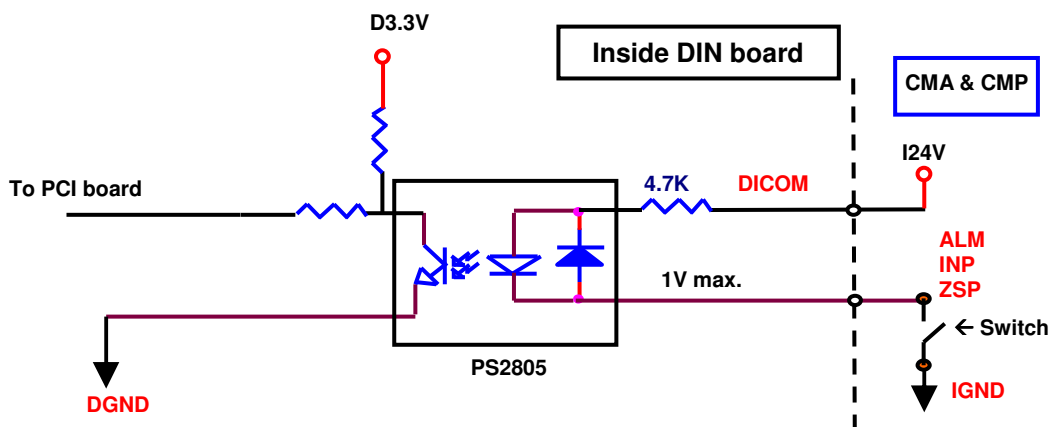

4. SVON:

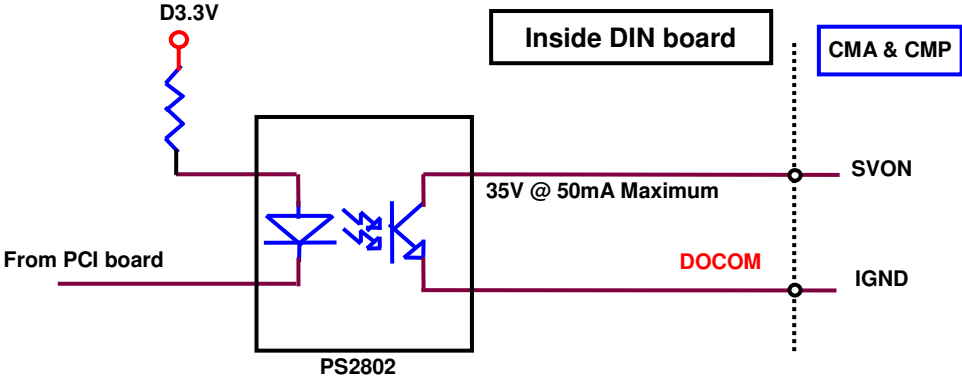

5. DO: General purposed digital output:

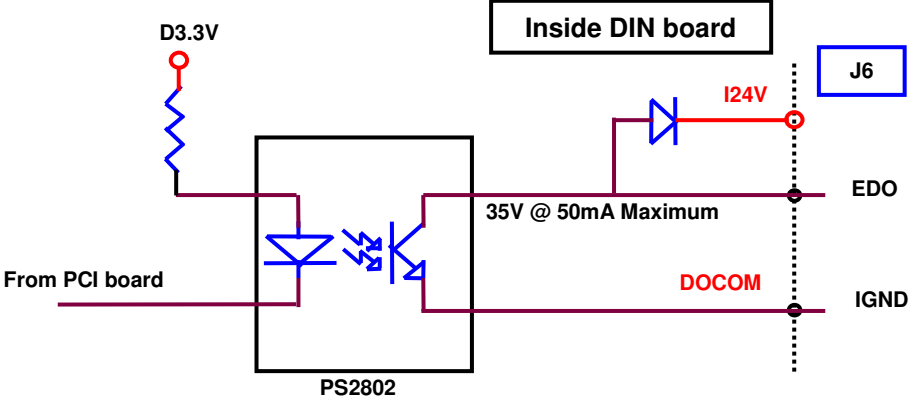

6. DI: from P2 connector

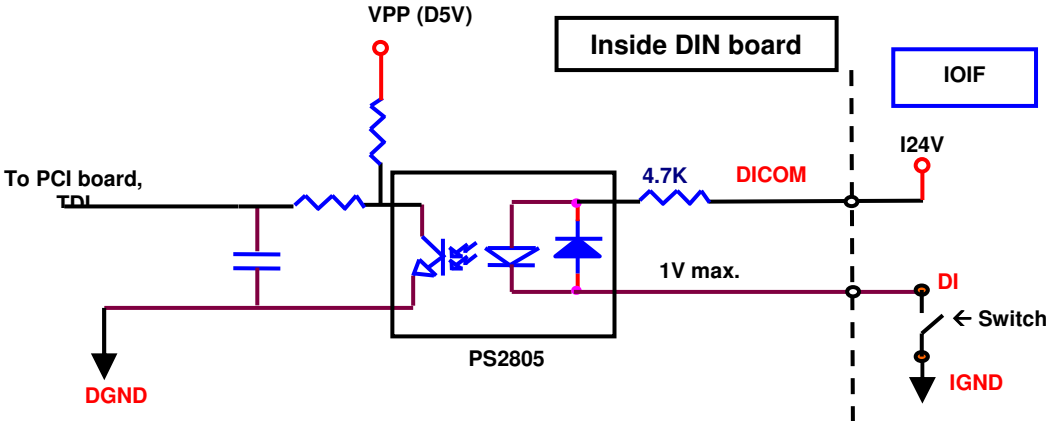

7. DO: from P2 connector

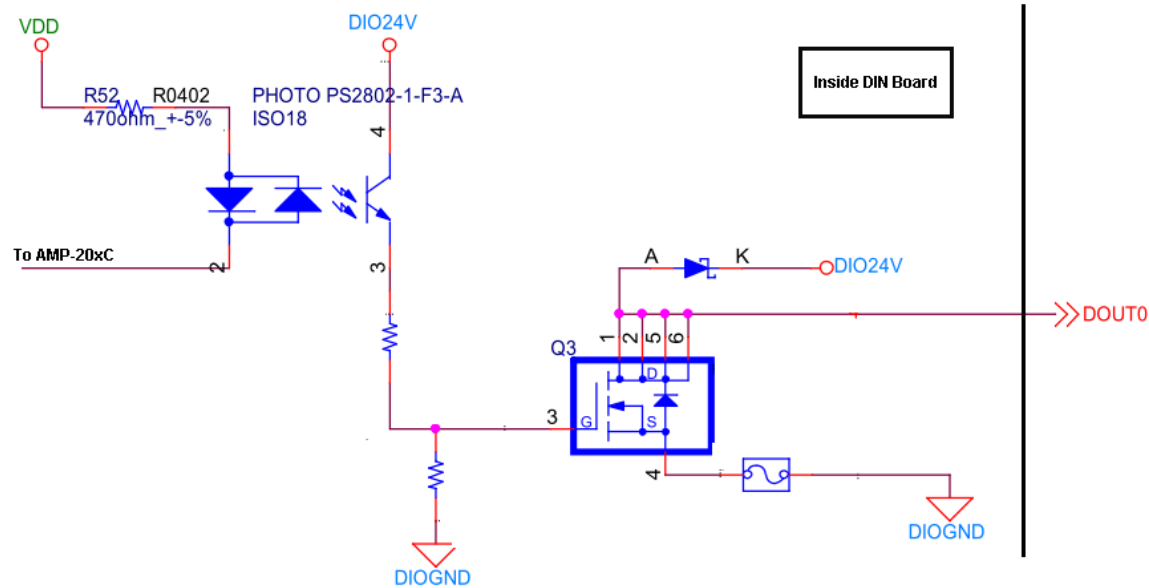

DOs were designed as High-Current Output to support up to 250mA current driving capacity to drive high-current valves or actuators. They are designed with MOSFET circuitry

**8. EA+、EB+、EZ+、EA-、EB-、EZ-**

The encoder feedback signals include EA, EB, and EZ. Every axis has six pins for three differential pairs of phase-A (EA), phase-B (EB), and index (EZ) inputs. EA and EB are used for position counting, and EZ is used for zero position indexing. Please note that the voltage across each differential pair of encoder input signals (EA+, EA-), (EB+, EB-), and (EZ+, EZ-) have ±7V common mode range. Therefore, the output current must be observed when connecting to the encoder feedback or motor driver feedback as not to over drive the source. The differential signal pairs are converted to digital signals EA, EB, and EZ; then feed to the motion controller. Below is example of connecting the input signals with an external circuit. The input circuit can be connected to an encoder or motor driver if it is equipped with: a differential line driver

➤ **Connection to Line Driver Output**

To drive the PCI-8254/58 encoder input circuitry, the driver output must provide at least 0.2V across the differential pairs. The case grounds of both sides must be tied together. The maximum frequency is 5MHz or more depends on wiring distance and signal conditioning.

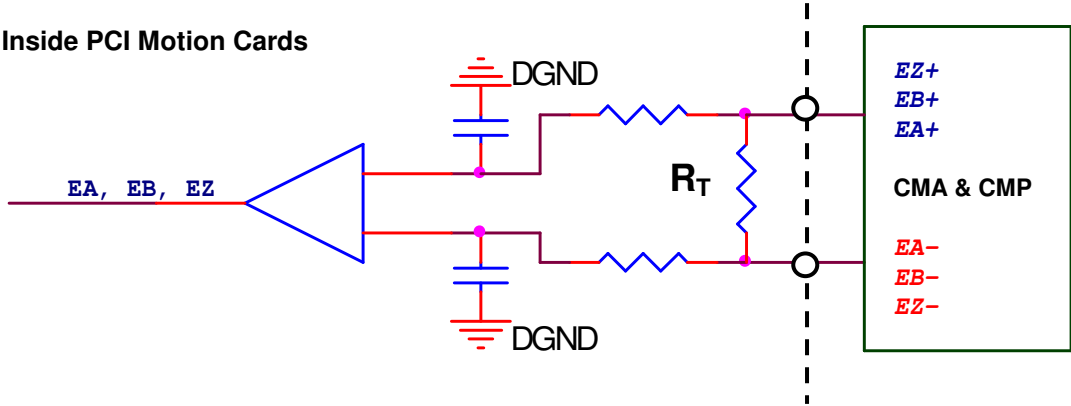

**9. TRG+、TRG-**

The PCI-8254/58 & AMP-204C/208C provides 2/4 comparison output channels. The comparison output channel will generate a pulse signal when the encoder counter reaches a pre-set value which set by the user.

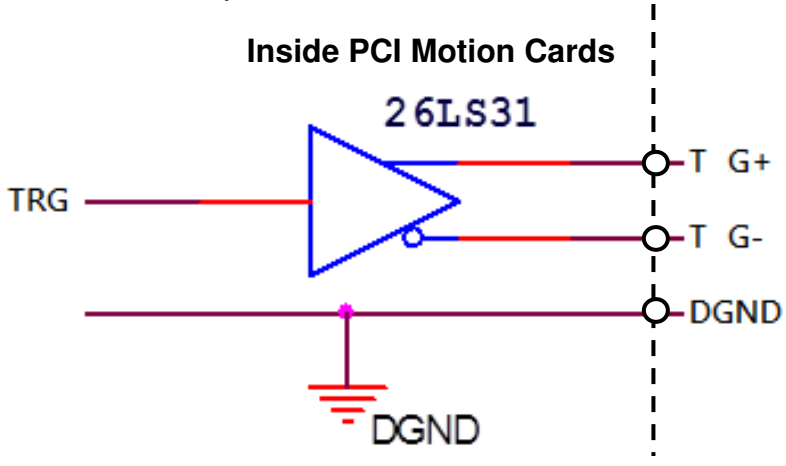

## 10. OUT/DIR +/-: Pulse Output Signals OUT and DIR

There are 4/8 axes pulse output signals. For each axis, two pairs of OUT and DIR differential signals are used to transmit the pulse train and indicate the direction. The OUT and DIR signals can also be programmed as CW and CCW signal pairs. In this section, the electrical characteristics of the OUT and DIR signals are detailed. Each signal consists of a pair of differential signals. For example, OUT1 consists of OUT1+ and OUT1- signals. The **default** setting of OUT and DIR is set to differential line driver mode. The following wiring diagram is for OUT and DIR signals of axis.

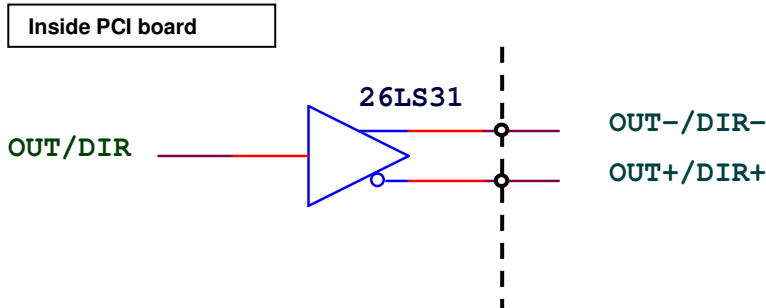

**Note:** Suggest Usage: See the following figure. Choose **OUT-/DIR-** to connect to driver's OUT/DIR

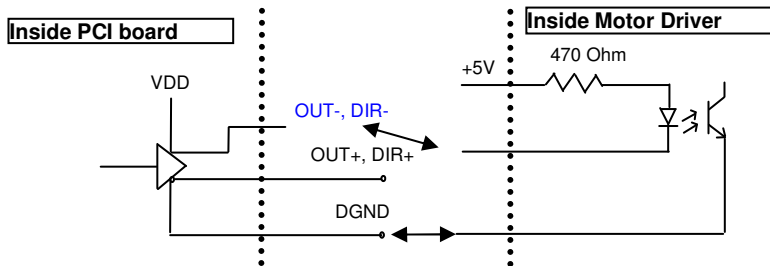

**Warning:** The sink current must not exceed 20mA or the 26LS31 will be damaged!

## 11. AOUT +/-: Differential analog signal

AOUT signal is used to drive the voltage command and indicate the direction. The AOUT signals can also decide motor forward/backward direction by plus/minus voltage output. The analog output can drive between +10V to -10V and its resolution guarantees to  $\pm 1\text{mV}$ .

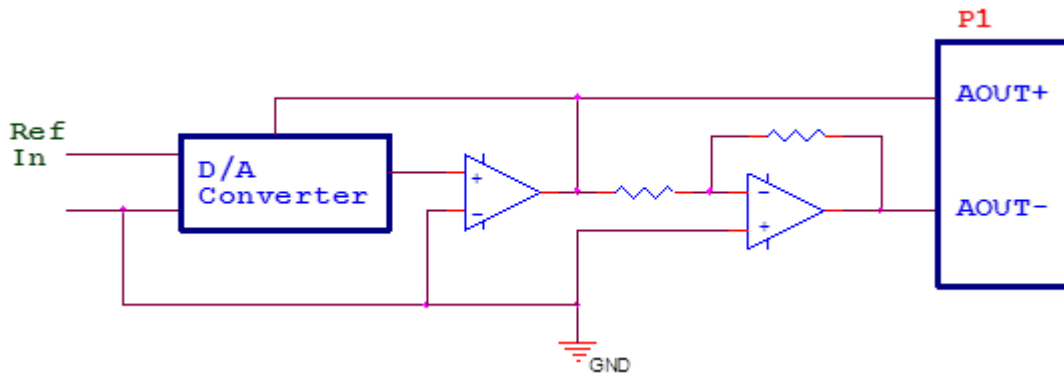

**Note**

The analog output channels are applicable on PCI-8254/8258 ONLY.

---

## 12. AIN: Analog input signal

AIN signal is used to receive the feedback voltage the direction. The analog input can indicate the voltage level between +10V to -10V and its resolution guarantees to 12bits with no missing code.

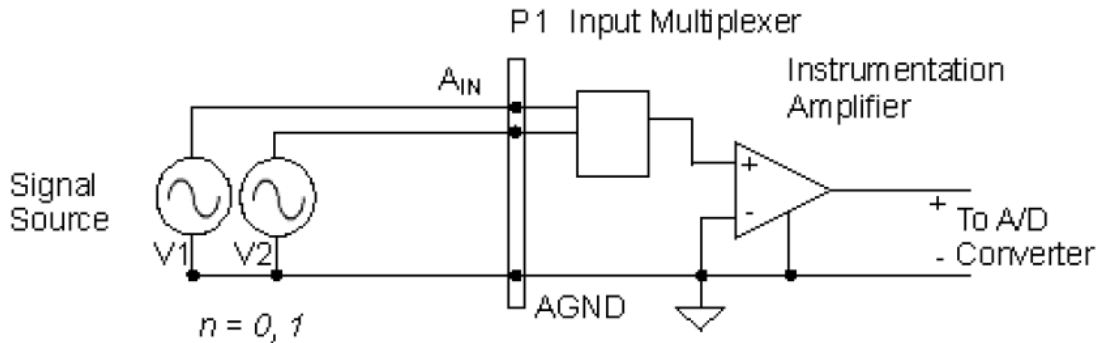
**Note**

The analog input channels are applicable on PCI-8254/8258 ONLY.

---